

SERVICE MANUAL

PARTS LIST

AKAI 4-CH/STEREO RECEIVER
MODEL **AS-960**



4-CH/STEREO RECEIVER

MODE **AS-960**

SECTION 1	SERVICE MANUAL	3
SECTION 2	PARTS LIST	33
SECTION 3	SCHEMATIC DIAGRAM	55

SECTION 1

SERVICE MANUAL

TABLE OF CONTENTS

I. SPECIFICATIONS	4
II. DISMANTLING OF UNIT	6
III. ARRANGEMENT OF MAIN PARTS	7
IV. NECESSARY MEASURING INSTRUMENTS	8
V. CLASSIFICATION OF VARIOUS P.C. BOARDS AND INTERCHANGEABILITY	9
VI. FM TUNER SECTION ADJUSTMENTS	10
1. FM IF CIRCUIT ADJUSTMENT	14
2. FRONT END AND FM IF MATCHING ADJUSTMENT	15
3. TRACKING ADJUSTMENT	15
4. SENSITIVITY ADJUSTMENT	16
5. STEREO SEPARATION ADJUSTMENT	16
6. TUNING METER CENTER ADJUSTMENT	16
7. STEREO INDICATOR SENSITIVITY ADJUSTMENT (MUTING LEVEL ADJUSTMENT)	17
VII. AM TUNER SECTION ADJUSTMENTS	18
1. AM IF CIRCUIT ADJUSTMENT	18
2. TRACKING ADJUSTMENT	19
3. SENSITIVITY ADJUSTMENT	20
VIII. TUNING CORD THREADING	21
IX. POWER AMPLIFIER ADJUSTMENTS	22
1. CURRENT ADJUSTMENT AT NON-INPUT	23
2. POWER TRANSISTOR VOLTAGE DISTRIBUTION ADJUSTMENT	23
X. COMPOSITE VIEWS OF COMPONENTS	27

I. SPECIFICATIONS

An asterisk next to a figure indicates the minimum guaranteed performance.

§ AMPLIFIER SECTION

RATED OUTPUT	4-CHANNEL 2-CHANNEL POWER DOUBLER	20W at 8Ω (1 channel operation 1 kHz 0.5%) 40W at 8Ω (1 channel operation 1 kHz 0.5%)
FREQUENCY RESPONSE	PHONO AUX	100 Hz 13.5±1.5 dB 10 kHz -13.5±1.5 dB 20 Hz/-2.0 dB, 50 kHz/-3.0 dB
POWER BAND WIDTH		10 Hz to 50 kHz at 8Ω
INPUT SENSITIVITY	PHONO MIC AUX TAPE 1 TAPE 2 CD-4	3 mV (-47.5±1.5 dB) 3 mV (-47.5±1.5 dB) 170 mV (-13±1.5 dB) 170 mV (-13±1.5 dB) 150 mV (-14.5±1.5 dB) 150 mV (-14.5±1.5 dB)
SIGNAL TO NOISE RATIO	PHONO MIC AUX-DISC 4 CH AUX-SQ TAPE 1, 2 CD-4	Better than 35 dB Better than 35 dB Better than 40 dB Better than 35 dB Better than 40 dB Better than 40 dB
RESIDUAL NOISE		Less than 4.3 mV (Less than -45 dB)
TONE CONTROL	BASS TREBLE	10±1.5 dB at 100 Hz -10±1.5 dB at 100 Hz 10±1.5 dB at 10 kHz -10±1.5 dB at 10 kHz
LOUDNESS CONTROL		8±2 dB at 100 Hz 4.5±2 dB at 10 kHz
CROSS TALK		Better than 50 dB
LEFT-RIGHT DEVIATION		Within 3 dB
FRONT-REAR DEVIATION		Within 3 dB
RECORDING OUTPUT	TAPE 1 DIN PIN TAPE 2 PIN	34 mV (-27±1.5 dB) 170 mV (-13±1.5 dB) 150 mV (-14.5±1.5 dB)
DISTORTION FACTOR		Less than 0.1% (8Ω 10W output)

§ SQ SECTION

	Input		F.L	F.R	R.L	R.R
CROSS TALK	F.L	1 kHz	0±2 dB	-15±2 dB	-2.5±2 dB	-2.5±2 dB
	F.R	1 kHz	-15±2 dB	0±2 dB	-2.5±2 dB	-2.5±2 dB
PHASE DEVIATION	F.L	1 kHz	0°		-115±20°	
	F.R	1 kHz		0°		+65±20°

§ FM SECTION

	Input		F.L	F.R	R.L	R.R
CROSS TALK	F.L	1 kHz	0±2 dB	-12±2 dB	-1±2 dB	-6±2 dB
	F.R	1 kHz	-12±2 dB	0±2 dB	-6±2 dB	-1±2 dB
PHASE DEVIATION	F.L	1 kHz	0°		+90±20°	
	F.R	1 kHz		0°		-90±20°

§ FM TUNER SECTION

FREQUENCY RANGE		J 75 to 91±1 MHz U 86 to 109±1 MHz
DIAL TRACKING ERROR		±250 kHz
SENSITIVITY (IHF)		2μV *Less than 4μV(Less than 12 dB)
SENSITIVITY DEVIATION		Within 3 dB
IMAGE REJECTION RATIO		65 dB *Better than 45 dB
IF REJECTION RATIO		90 dB *Better than 60 dB
SPURIOUS REJECTION RATIO		Better than 60 dB
CAPTURE RATIO (IHF)		Less than 2 dB
SELECTIVITY		65 dB *Better than 60 dB
AM SUPPRESSION RATIO		Better than 45 dB
SIGNAL TO NOISE RATIO	MONAURAL STEREO	70 dB *Better than 55 dB Better than 45 dB
DISTORTION FACTOR	MONAURAL STEREO	0.4% *Less than 0.5% 0.8% *Less than 2.0%
FREQUENCY RESPONSE		J -11±1.5 dB at 10 kHz U -13.0 dB at 10 kHz
STEREO SENSITIVITY		45 μV (33±3 dB)
STEREO INDICATOR SENSITIVITY		32 μV (30±3 dB)
STEREO SEPARATION		40 dB *Better than 33 dB
REJECTION RATIO		Better than 45 dB
L-R DEVIATION		Within 3 dB
RECORDING OUTPUT	PIN DIN	170 mV (-13±1.5 dB) 35 mV (-27±1.5 dB)

§ AM TUNER SECTION

FREQUENCY RANGE		525±5 kHz to 1,650±20 kHz
DIAL TRACKING ERROR		Within 2%
SENSITIVITY (IHF)		250 μV *Less than 350 μV (Less than 50 dB)
SENSITIVITY DEVIATION		Within 6 dB
IMAGE REJECTION RATIO		55 dB *Better than 50 dB
IF REJECTION RATIO		Better than 45 dB
SELECTIVITY		Better than 30 dB
SIGNAL TO NOISE RATIO		50 dB *Better than 40 dB
DISTORTION FACTOR		Less than 1.5%
FREQUENCY RESPONSE		-15 dB at 3 kHz

§ OTHER

Transistors	2SA684 ... 4 2SA733 (P) (Q) (R) ... 1 2SC454 ... 3 2SC839 (E) (F) ... 4 2SC922 ... 1	2SC945 (P) (Q) (R) ... 4 2SC1312 (F) (G) ... 20 2SC1318 (P) (Q) ... 4 2SC1384 (Q) (R) ... 4 2SD313 (E) (F) ... 9
I.C.	LA-3300 ... 1	TA-7061AP ... 1
DIODES	1N34A ... 3 1N60 ... 6	10D1 ... 12 HIFI 400V 3A ... 4
ZENER DIODES	WZ-120 ... 1	WZ-130 ... 1
VARISTORS	STV-3H ... 4	
POWER SOURCE	100 to 240V A.C. 50/60 Hz 120V A.C. 60 Hz (CSA Models)	
POWER CONSUMPTION	300W/4Ω (at maximum output) 160W/4Ω (at 1/3 output)	
DIMENSIONS	480 (W)x168(H)x402(D) mm (18.9"x6.6"x15.8")	
WEIGHT	13.06 kg (28.7 lbs.)	

NOTE: Specifications subject to change without notice.

II. DISMANTLING OF UNIT

In case of trouble, etc. necessitating disassembly, please disassemble in the order shown in photographs. Re-assemble in reverse order.

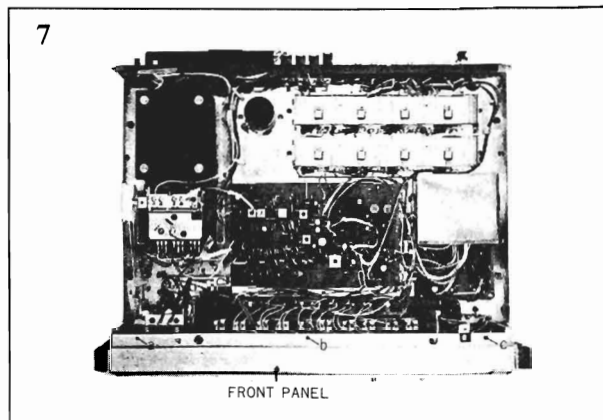
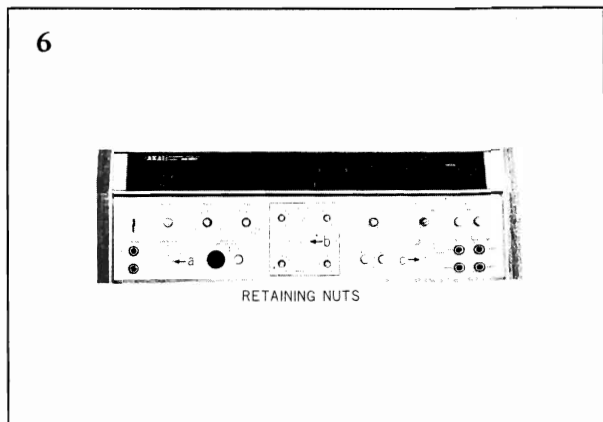
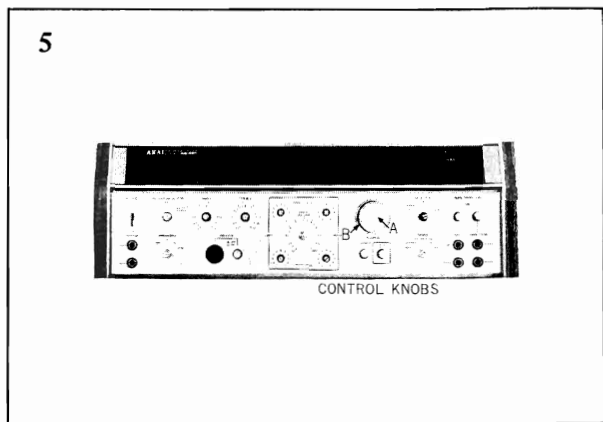
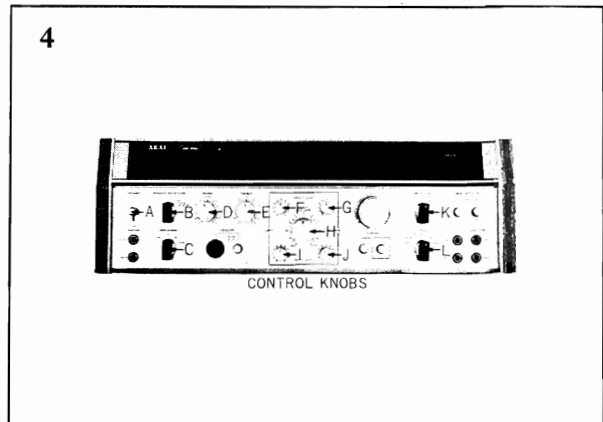
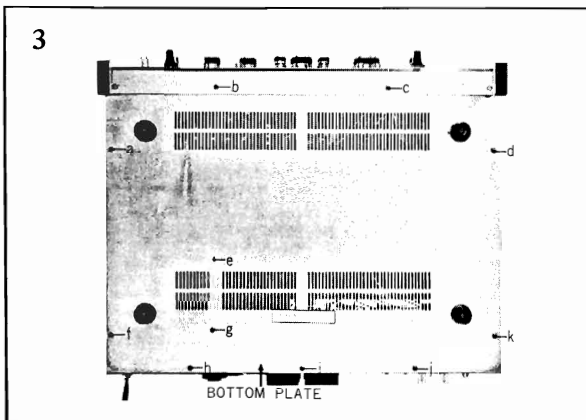

III. ARRANGEMENT OF MAIN PARTS

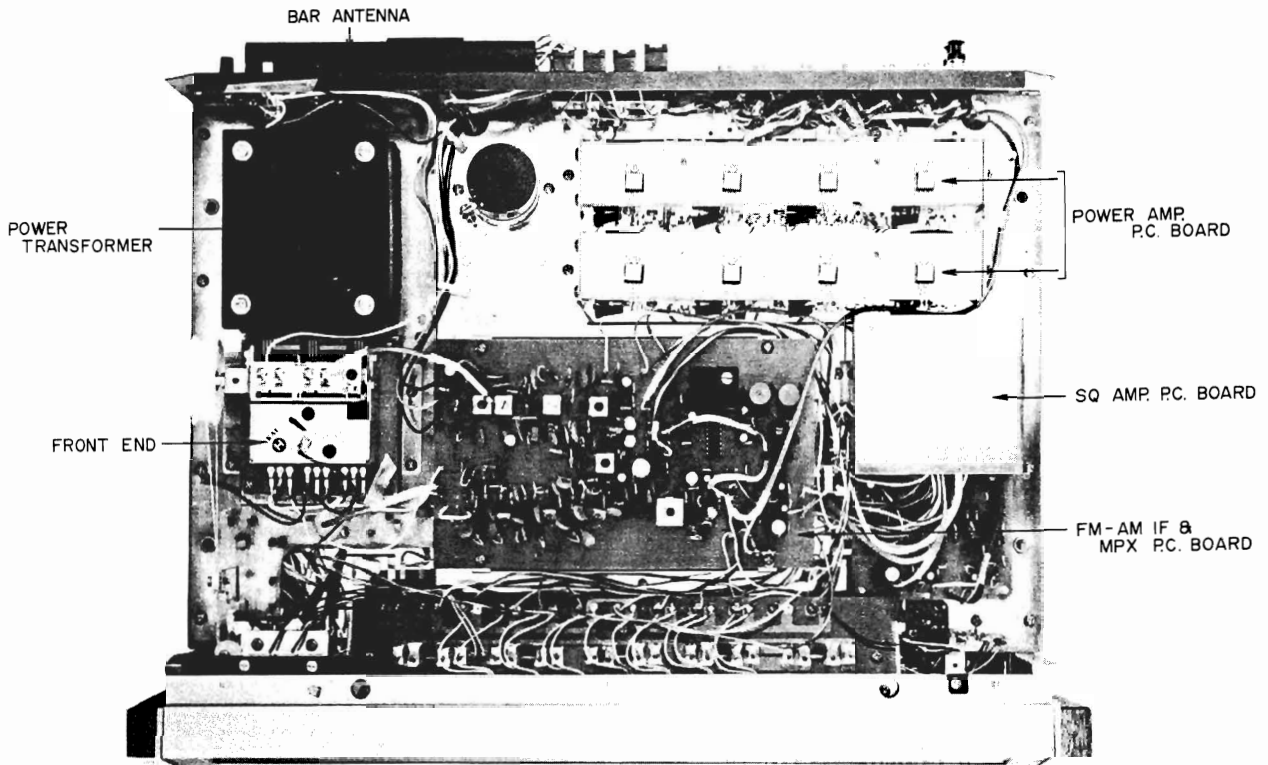

Fig. 1

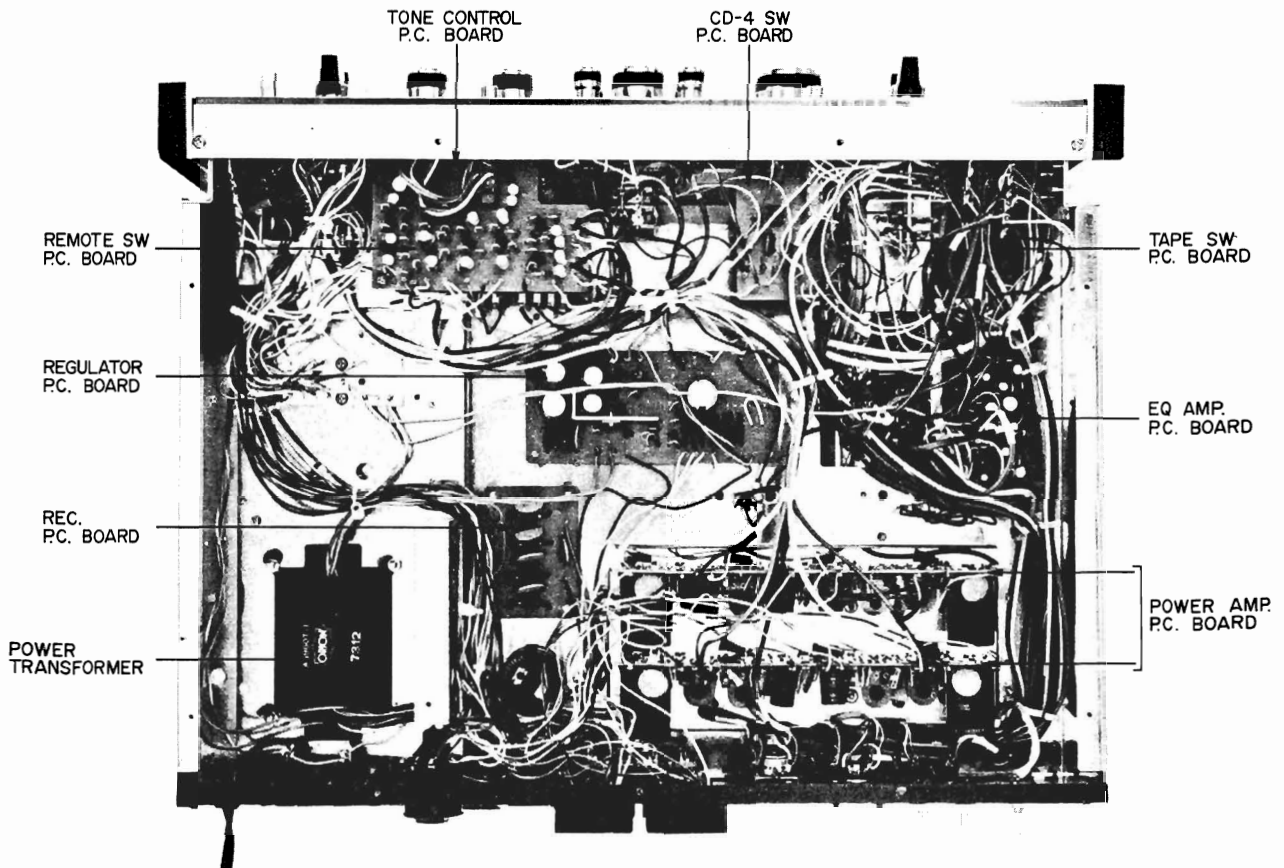

Fig. 2

IV. NECESSARY MEASURING INSTRUMENTS

Measuring Instrument	Model	For
AM-FM Radio IF Genescope	Meguro MSW-721C	FM and AM IF Adjustment
FM Standard Signal Generator	Meguro MSG-278G	FM Tracking, Sensitivity Adjustment
FM Stereo Modulator	Meguro MSG-211E	Stereo Separation Adjustment
AM Standard Signal Generator	Meguro MSG-221C	AM Tracking, Sensitivity Adjustment
AM Loop Antenna	Meguro MLA-1001B	AM Tracking, Sensitivity Adjustment
High Sensitivity V.T.V.M.	Kikusui 183E	Sensitivity, Stereo Separation Adjustment
Distortion Meter	Shibasoku 760C	Sensitivity Adjustment
Ampere Meter	Yokogawa 2011	Power Amp. Adjustment

Chart 1

V. CLASSIFICATION OF VARIOUS P.C. BOARDS AND INTERCHANGEABILITY

P.C. Board		Model			
		AS-980	AS-970	AA-910	AA-910DB
TAPE SWITCH P.C. BOARD	96-5001	98-5002	97-5004		
CD-4 SWITCH P.C. BOARD	96-5003	98-5004	97-5003		
EQ. AMP. P.C. BOARD	96-5004	98-5008	98-5008	91-5034	91-5034
LOUDNESS P.C. BOARD	96-5005	98-5016			
TONE CONTROL P.C. BOARD	96-5006	98-5007	98-5007	91-5036	91-5036
FRONT END P.C. BOARD	96-5007				
POWER AMP. P.C. BOARD	96-5008	92-5005	97-5009	91-5030	91-5030
RECT. P.C. BOARD	98-5010	98-5010	98-5010		
HEAD PHONE P.C. BOARD	98-5012	98-5012	98-5012		
DUB. P.C. BOARD	98-5013	98-5013			
MIC. P.C. BOARD	98-5059	98-5059			
REGULATOR P.C. BOARD	98-5084	98-5084*	98-5084*		
DIAL ILLUMINATION P.C. BOARD	97-5008	98-5001	97-5008	91-5035	91-5035
SQ AMP. P.C. BOARD	97-5010	98-5015	97-5010		
FM-AM IF & MPX. P.C. BOARD	91-5033			91-5033	91-5033

NOTE: * . . . No interchangeable

Chart 2

VI. FM TUNER SECTION ADJUSTMENTS

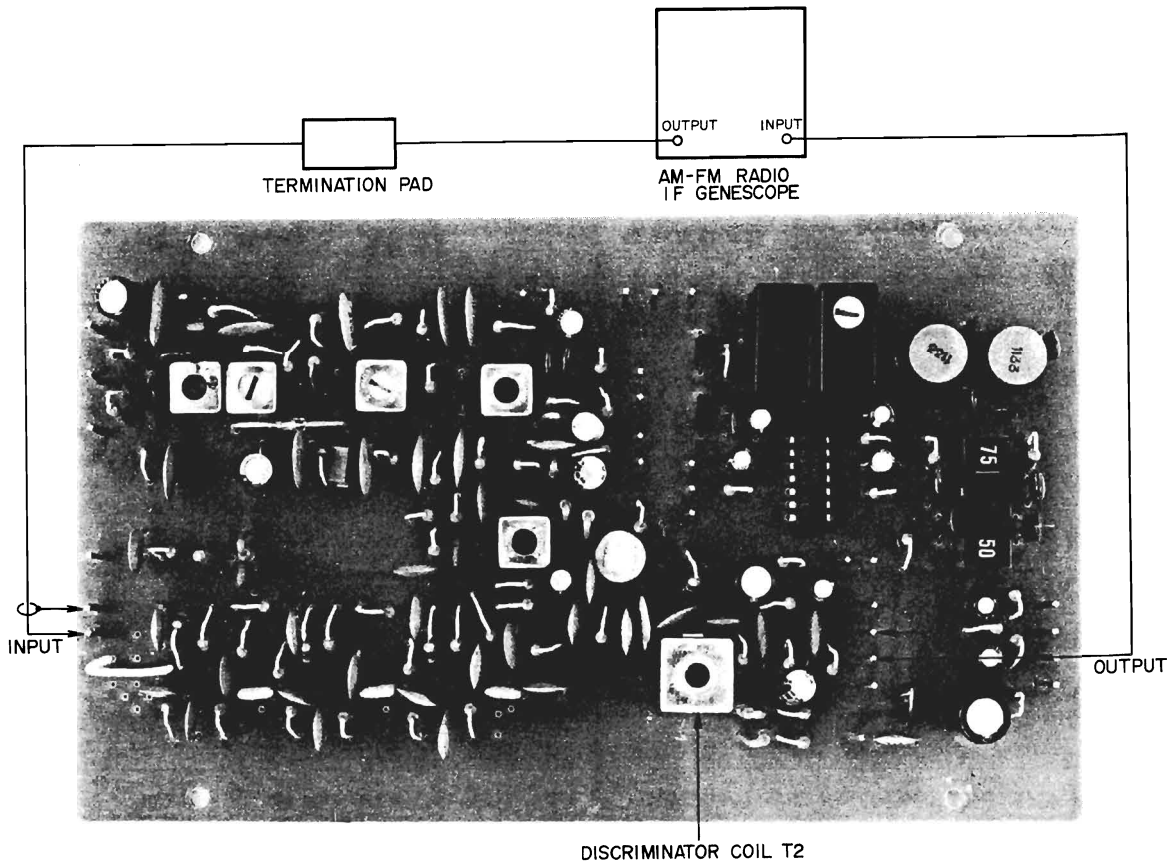

Fig. 3 INSTRUMENT CONNECTIONS

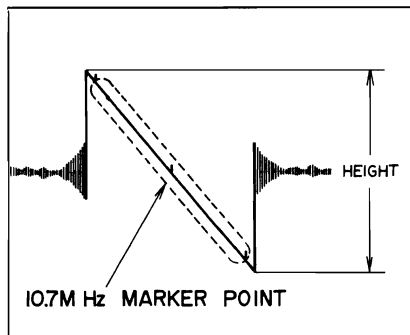
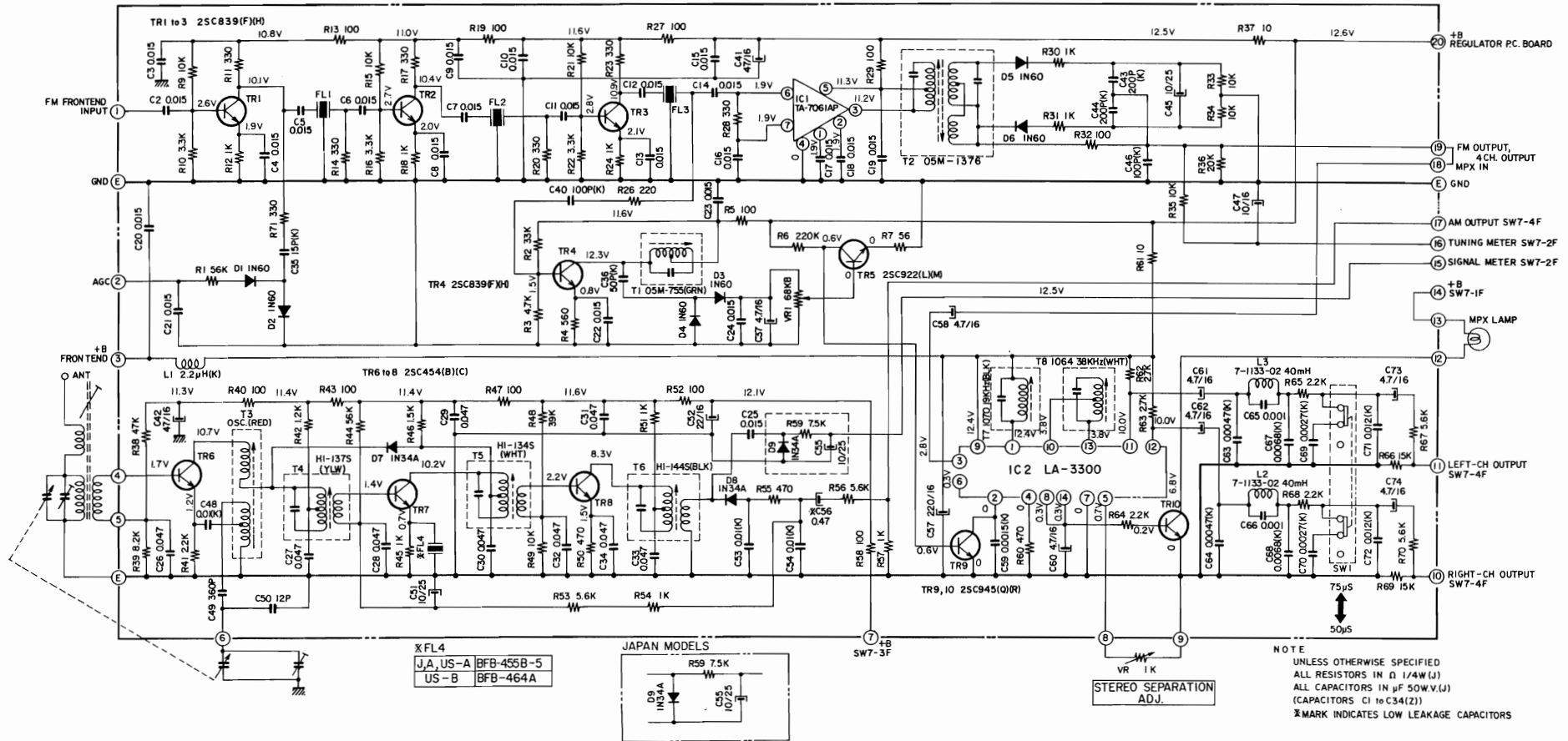

Fig. 4 S Curve

Vertical Gain	0.3Vp-p to 1 cm
Genesco Output Level	50 to 60 dB
Discriminator Coil	T2
S Curve Height	5 to 6 cm

Chart 3

FM - AM IF & MPX P.C. BOARD 91-5033



SCHEMATIC 1

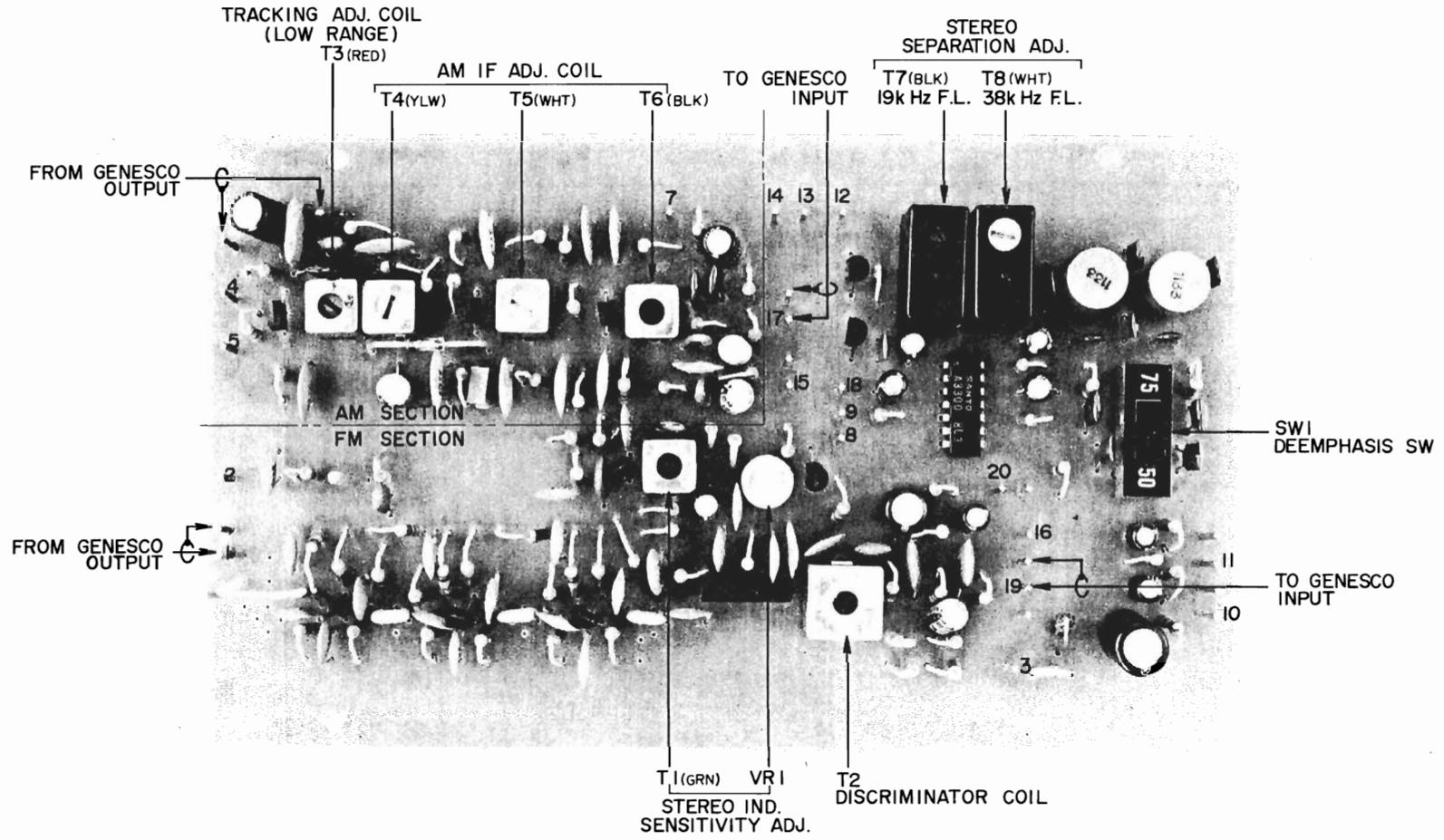
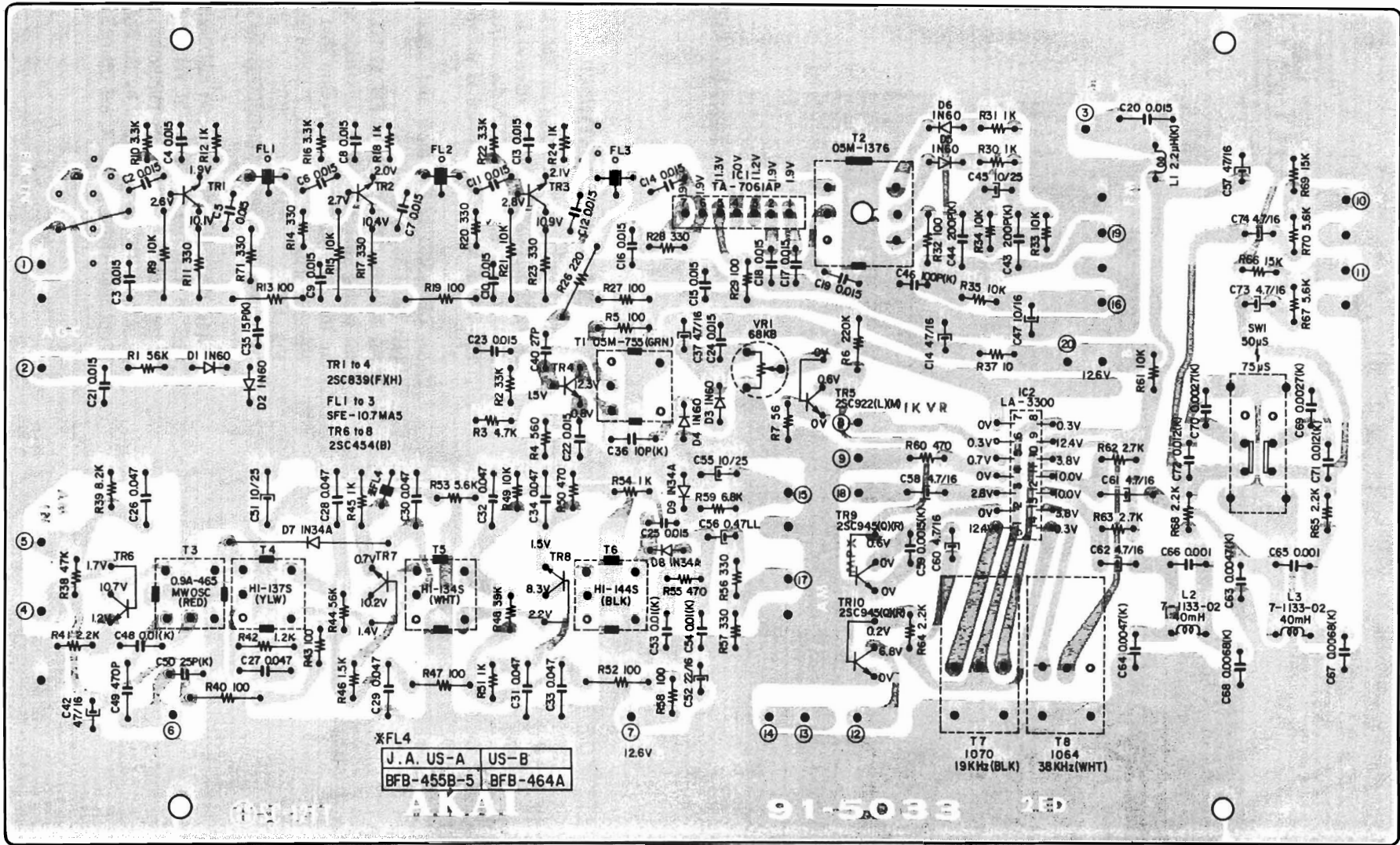

Fig. 5 FM-AM IF & MPX P.C. BOARD 91-5033 (Face)



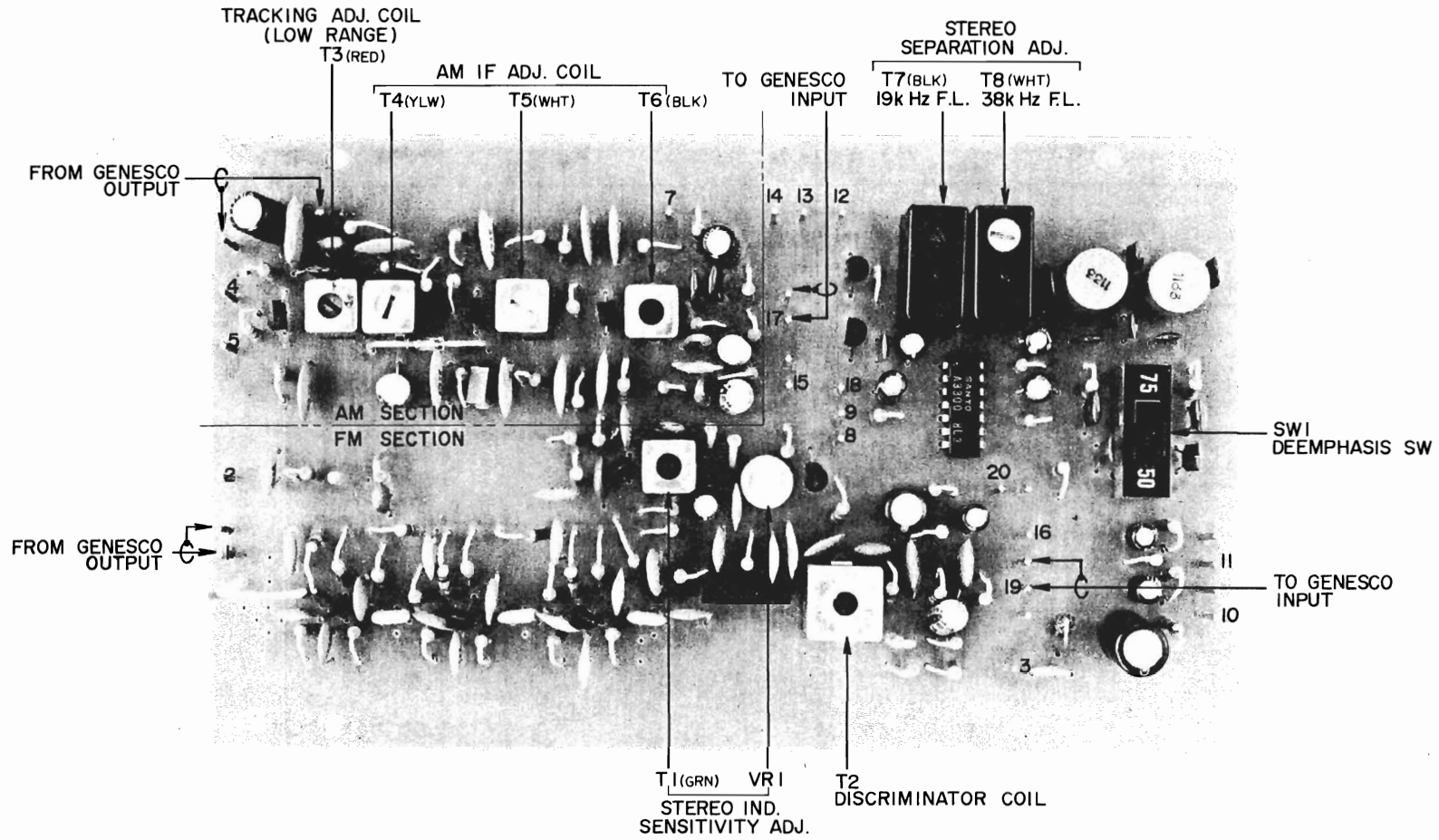

Fig. 5 FM-AM IF & MPX P.C. BOARD 91-5033 (Face)

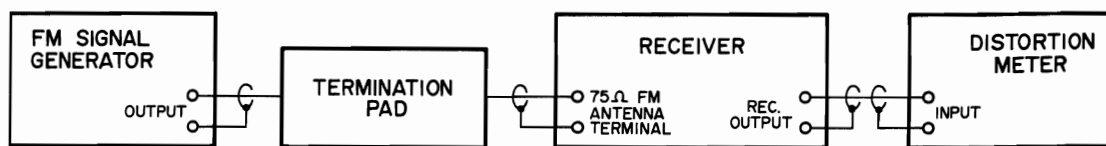

Fig. 9 INSTRUMENT CONNECTIONS

Ref. In making Tracking Adjustments, set dial to following positions.

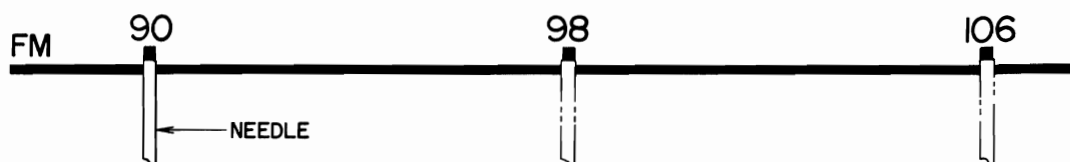

Fig. 10

2. FRONT END AND FM IF MATCHING ADJUSTMENT

- 1) Connect the GENESCO lead wires to the 75Ω FM ANTENNA TERMINALS of the Receiver as well as to the FM-AM IF & MPX P.C. Board output as shown in Fig. 7.
- 2) Set the GENESCO to FM mode and adjust the V gain of GENESCO to obtain a 10 mm amplitude of the 0.3Vp-p calibration voltage on GENESCO screen and set the attenuator to 100 dB.
- 3) Set Receiver SELECTOR to FM AUTO, and set the tuning indicator needle to extreme right end of the dial.
- 4) Adjust the upper core of Front End IF Coil (see Fig. 16) to obtain maximum wave height value of S Curve in Fig. 8, and adjust the lower core to obtain maximum noise level.
- 5) Make this adjustment again following FM Sensitivity Adjustment.

FM S.G. Output	46 dB
Core (low range)	Lo
Trimmer Condenser (high range)	TCo

Chart 4

3. TRACKING ADJUSTMENT

- 1) Connect the various measuring instruments as shown in Fig. 9.
- 2) Set the oscillation frequency of the FM SIGNAL GENERATOR (hereinafter referred to FM S.G.) to 90 MHz (400 Hz 100% internal modulation), and set the output of the FM S.G. to 46 dB. (Refer to Chart 4)
- 3) Set Receiver SELECTOR to FM AUTO, and set the tuning indicator needle to 90 MHz. (Refer to Fig. 10)
- 4) Adjust Coil Lo of Front End (Fig. 16) until the distortion meter level is maximum and the distortion factor is minimum. (Refer to Chart 4)
- 5) Set the oscillation frequency of FM S.G. and tuning indicator needle to 106 MHz. (Refer to Fig. 10)
- 6) Adjust Trimmer Condenser TCo of Front End (Fig. 16) until the distortion meter level is maximum and the distortion factor is minimum. (Refer to Chart 4)
- 7) Repeat adjustments outlined in Items 2) through 6) two or three times for minimum tracking error.

Core (low range)	LR
Trimmer Condenser (high range)	TCA, TCR
IF Coil (mid range)	IF
Discriminator Coil (mid range)	T2

Chart 5

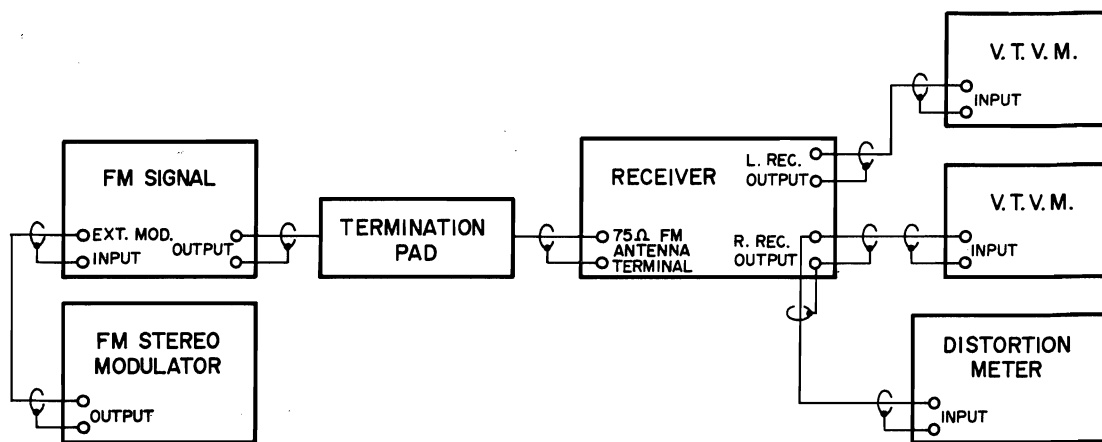

Fig. 11 INSTRUMENT CONNECTIONS

4. SENSITIVITY ADJUSTMENT

- 1) Carry out these adjustments after the previously described Tracking Adjustments have been completed.
- 2) Measuring instrument connections are the same as described in Tracking Adjustments.
- 3) Set the oscillation frequency of the FM S.G. to 90 MHz (400 Hz, 100% internal modulation), set Receiver Selector to FM-AUTO, and set the tuning indicator needle to 90 MHz. (Refer to Fig. 10)
- 4) Adjust the FM S.G. Attenuator to obtain a 3% distortion factor.
- 5) Adjust Coil LR of front end (Fig. 16), until the distortion meter level is maximum and the distortion factor is minimum. (Refer to Chart 5)
- 6) Set the oscillation frequency of FM S.G. and tuning indicator needle to 106 MHz. (Refer to Fig. 10)
- 7) Adjust the FM S.G. Attenuator to obtain a 3% distortion factor.
- 8) Adjust Trimmer Condensers TCA, TCR of front end (Fig. 16), until the distortion meter level is maximum and the distortion factor is minimum. (Refer to Chart 5)
- 9) Set the oscillation frequency of FM S.G. and the tuning indicator needle to 98 MHz. (Refer to Fig. 10)
- 10) Adjust the FM S.G. Attenuator to obtain a 3% distortion factor.
- 11) Adjust the upper and lower core of IF Coil in front end (Fig. 16) and the lower core of FM-AM IF & MPX P.C. Board Discriminator Coil until the distortion meter level is maximum and the distortion factor is minimum. (Refer to Chart 5)
- 12) Repeat adjustments outlined in Items 3) through 11) at 90 MHz, 98 MHz, and 106 MHz two or three times for highest sensitivity.

5. STEREO SEPARATION ADJUSTMENT

- 1) Connect the various measuring instruments as shown in Fig. 11.
- 2) Set the FM STEREO MODULATOR pilot signal 19 kHz to 10%, and the main signal 400 Hz (left channel + right channel) to 90% modulation, and supply this composite signal (ratio 9:1) to the EXT MOD input terminal of the FM S.G.
- 3) Set the oscillation frequency of the FM S.G. to 98 MHz, and the attenuator to 66 dB.
- 4) Set Receiver SELECTOR to FM AUTO and the tuning indicator needle to 98 MHz to receive the FM S.G. Signal.
- 5) Set the output signal selector of FM STEREO MODULATOR to SUB.
- 6) Adjust the cores of FM-AM IF & MPX P.C. BOARD 19 kHz Filter T7(BLK), and 38 kHz Filter T8(WHT) until the distortion factor is minimum. (Refer to Fig. 5)
- 7) Set the output signal selector of FM STEREO MODULATOR to left channel.
- 8) Adjust the MPX Adjustment Volume located on rear panel of the Receiver until the right channel output level is minimum.

6. TUNING METER CENTER ADJUSTMENT

After completing the adjustments outlined in Parts 1 through 4 of this manual, set the FM S.G. Attenuator to non-output condition, and adjust the upper core of FM-AM IF & MPX P.C. Board Discriminator Coil T2 shown in Fig. 5 until the tuning indicator needle of tuning meter comes to the center. Then set Receiver dial to 98 MHz, supply a 98 MHz (400 Hz, 100% internal modulation) 66 dB signal from the FM S.G. and fine adjust the lower core of Discriminator Coil T2 for minimum distortion factor.

7. STEREO INDICATOR SENSITIVITY ADJUSTMENT (MUTING LEVEL ADJUSTMENT)

- 1) Connect the various measuring instruments as shown in Fig. 11.
- 2) Set the FM S.G. oscillation frequency to 98 MHz (400 Hz, 100% internal modulation) and Attenuator to non-output condition.
- 3) Set Receiver dial to 98 MHz. (There will be no output at either channel)
- 4) Adjust FM-AM IF & MPX P.C. Board Semi-fixed Resistor VR1 68 kB so that when the attenuation decreases and the Attenuator scale is at 30 dB signal output is emitted at both channels.

VII. AM TUNER SECTION ADJUSTMENTS

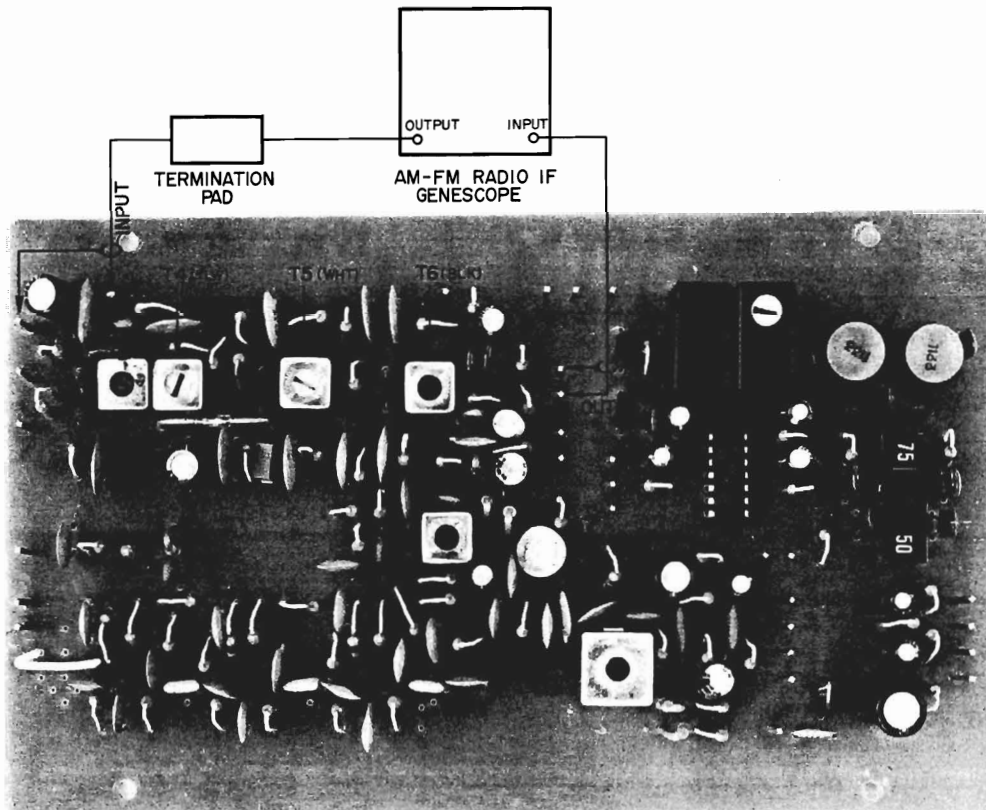

Fig. 12 INSTRUMENT CONNECTIONS

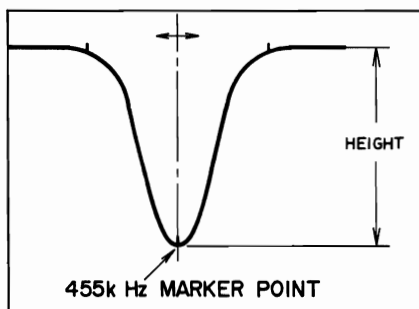

Fig. 13

Vertical Gain	0.3V _{p-p} to 3 cm
GENESCO Output Level	96 dB
Single Peaked Curve Height	2 cm

Chart 6

1. AM IF CIRCUIT ADJUSTMENT

- 1) Connect the AM-FM Radio IF GENESCOPE (hereinafter referred to as GENESCO) lead wires to input terminal as well as output terminal of the FM-AM IF & MPX P.C. Board as shown in Fig. 12.
- 2) Set GENESCO to AM mode and adjust vertical gain. (Refer to Chart 6)
- 3) Set Receiver SELECTOR to AM and set the tuning indicator needle to extreme right end of dial.

NOTE: A Noise Element should not enter the single peaked curve shown in Fig. 13.

- 4) Adjust output level of GENESCO. (Refer to Chart 6)
- 5) Adjust the core of FM-AM IF & MPX P.C. Board IFT T6(BLK) (Refer to Fig. 5) so that the 455 kHz marker point of the single peaked curve displays maximum amplitude as shown in Fig. 13.
- 6) Adjust the cores of FM-AM IF & MPX P.C. Board IFT T5(WHT), T4(YLW) (refer to Fig. 5) so that the left and right rise up characteristics of the single peaked curve shown in Fig. 13 are identical from the center (indicated by the dotted line in the figure).
- 7) In making this adjustment, the single peaked curve marker point will differ according to the rank of the ceramic filter.

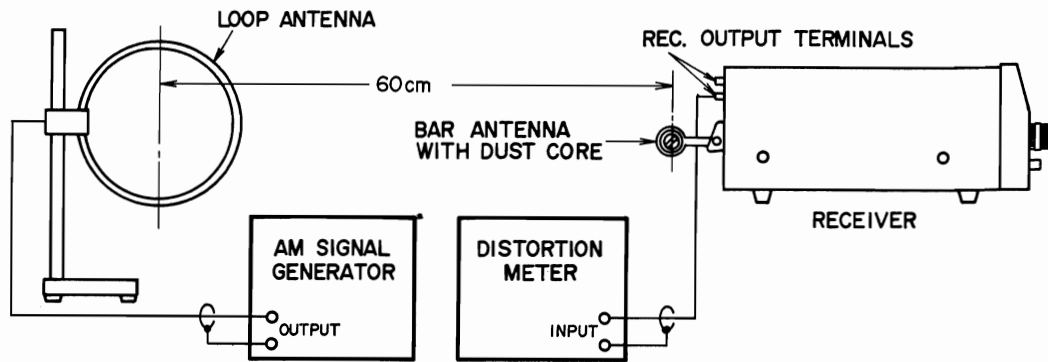

Fig. 14 INSTRUMENT CONNECTIONS



Ref. In making Tracking Adjustments, set dial to following positions.

Fig. 15

AM S.G. Output	60 dB
Core (low range)	T3 (RED)
Trimmer Condenser (high range)	TC1

Chart 7

Bar Antenna Dust Core (low range)	ANT1
Trimmer Condenser (high range)	TC2

Chart 8

2. TRACKING ADJUSTMENT

- 1) Connect the various measuring instruments as shown in Fig. 14.
- 2) Set the oscillation frequency of the AM SIGNAL GENERATOR (hereinafter referred to as AM S.G.) to 600 kHz (400 Hz 30% internal modulation) and adjust the AM S.G. Attenuator. (Refer to Chart 7)
- 3) Set Receiver SELECTOR to AM and set the tuning indicator needle to 600 kHz. (Refer to Fig. 15)
- 4) Adjust the core of FM-AM IF & MPX P.C. Board Tracking Adjustment Coil T3 (RED) in Fig. 5 until the distortion meter level is maximum and the distortion factor is minimum.
- 5) Set the oscillation frequency of AM S.G. and tuning indicator needle of Receiver to 1,400 kHz. (Refer to Fig. 15)
- 6) Adjust front end Trimmer Condenser TC1 in Fig. 16 until the distortion meter level is maximum and the distortion factor is minimum. (Refer to Chart 7)
- 7) Repeat adjustments outlined in Items 2) through 6) two or three times for minimum tracking error.

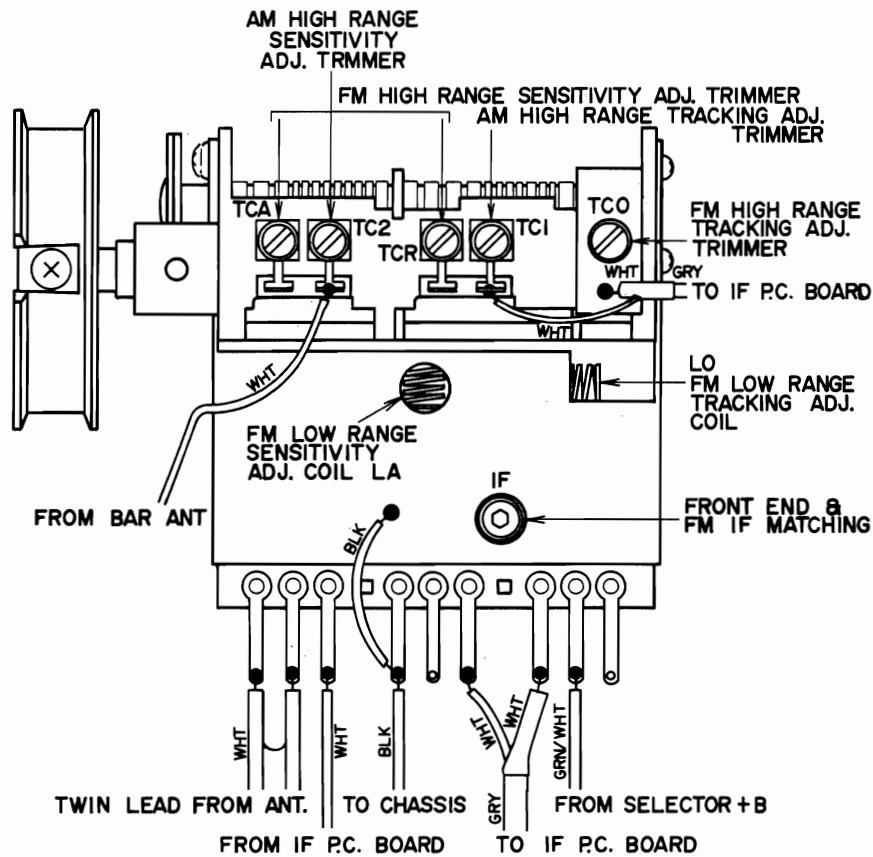

Fig. 16

3. SENSITIVITY ADJUSTMENT

- 1) Carry out these adjustments after the previously described Tracking Adjustments have been completed.
- 2) Measuring instrument connections are the same as described in Tracking Adjustments. (Refer to Fig. 14)
- 3) Set the oscillation frequency of the AM S.G. to 600 kHz (400 Hz, 30% internal modulation). Set Receiver SELECTOR to AM and the tuning indicator needle to 600 kHz. (Refer to Fig. 15)
- 4) Adjust AM S.G. Attenuator to obtain a 10% distortion factor.
- 5) Adjust dust core of Bar Antenna shown in Fig. 14 until the distortion meter level is maximum and the distortion factor is minimum.
- 6) Set the oscillation frequency of AM S.G. and Tuning indicator needle to 1,400 kHz. (Refer to Fig. 15)
- 7) Adjust AM S.G. Attenuator to obtain a 10% distortion factor.
- 8) Adjust front end Trimmer Condenser TC2 in Fig. 16 until the distortion meter level is maximum and the distortion factor is minimum. (Refer to Chart 8)
- 9) Repeat adjustments outlined in Items 3) through 8) at 600 kHz and 1,400 kHz two or three times for highest sensitivity.

VIII. TUNING CORD THREADING

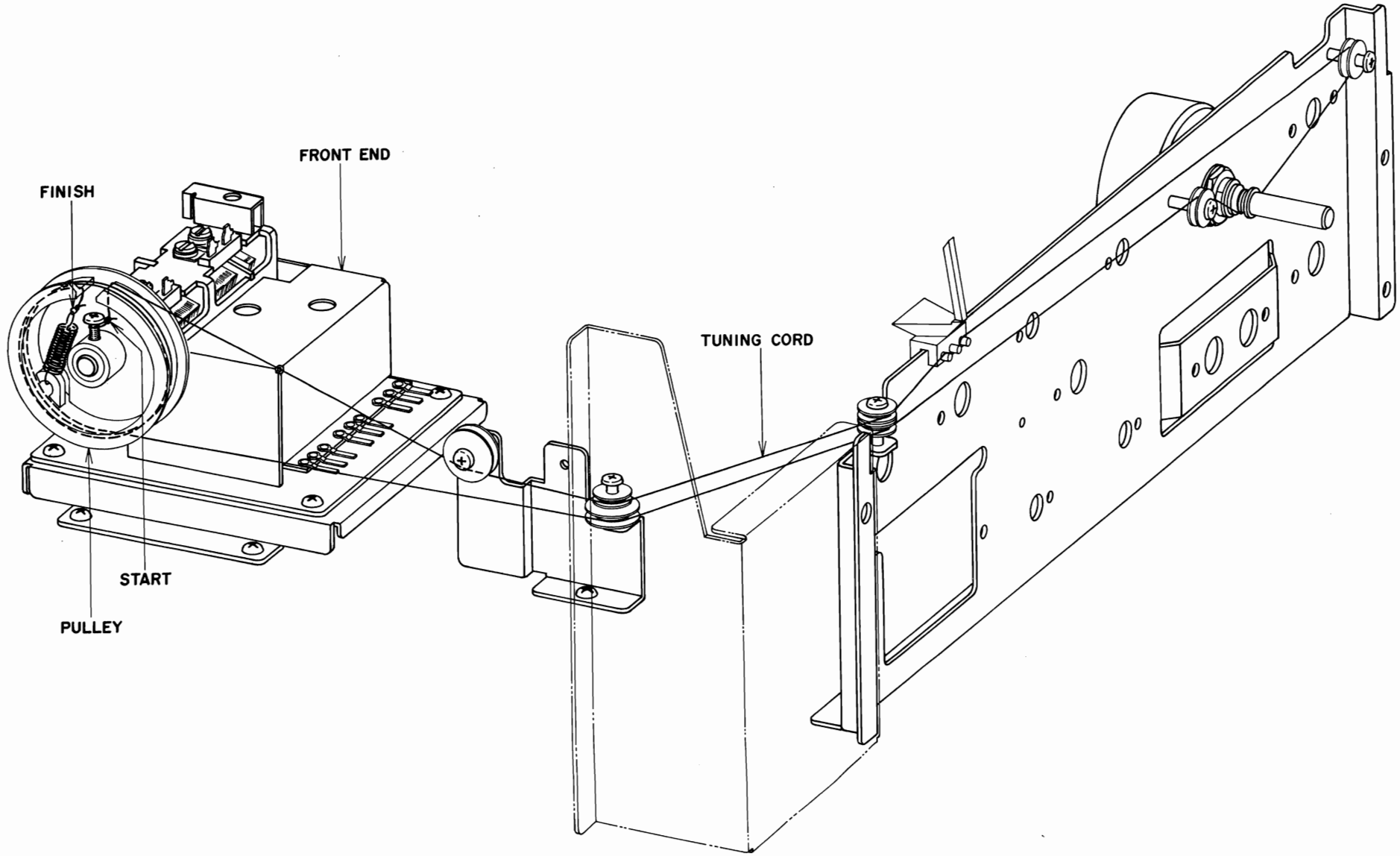

Fig. 17

IX. POWER AMPLIFIER ADJUSTMENTS

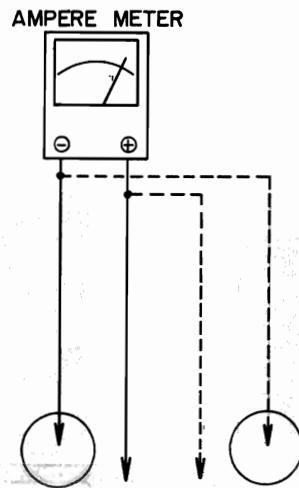

Fig. 18 ○ INDICATES SOLDERING POINTS

1. CURRENT ADJUSTMENT AT NON-INPUT

* Turn Volume Control to minimum and proceed as follows:

- 1) Remove solder from soldering point of Power Amp. P.C. Board shown in Fig. 18.
- 2) Connect a 50 to 100 mA scale Ampere Meter as shown in Fig. 18.
(Be sure to match Ampere Meter polarities)
- 3) Adjust Power Amp. P.C. Board semi-fixed resistor VR2 100B shown in Fig. 19 to obtain an Ampere Meter indication of 40 mA.

2. VOLTAGE ADJUSTMENT BETWEEN POWER TRANSISTORS C-E

* Refer to Schematic Diagram

- 1) Connect Voltage Meter to Power Amp. P.C. Board TR6 Collector and terminal 8 shown in Fig. 19.
- 2) Adjust Power Amp. P.C. Board semi-fixed resistor VR1 30 kB shown in Fig. 19 so that the Voltage Meter indication is 1/2 of the supply voltage value.

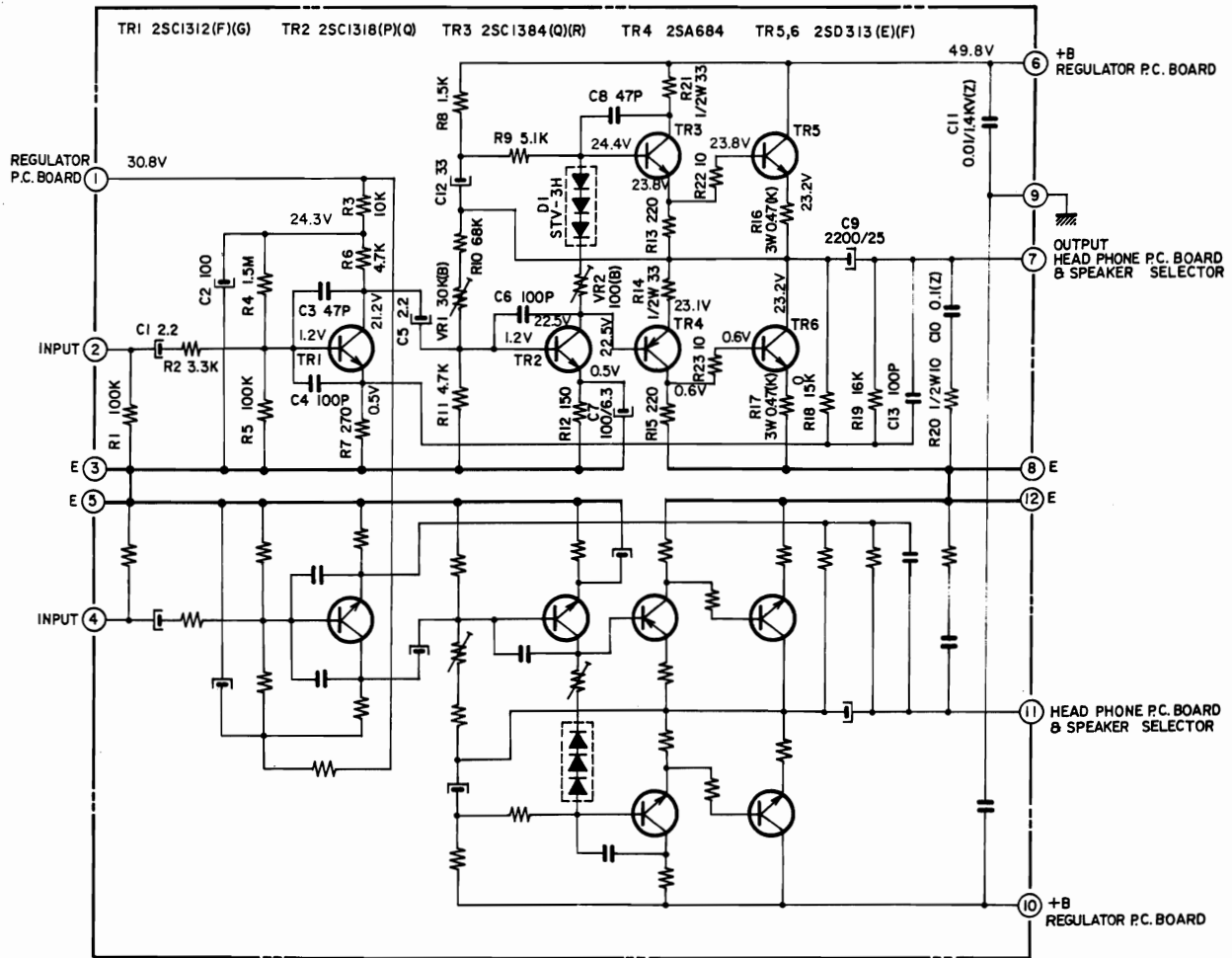

POWER AMP. P.C. BOARD 96-5008

NOTE
 UNLESS OTHERWISE SPECIFIED
 ALL RESISTORS IN Ω, 1/4W(J)
 ALL CAPACITORS IN μF 50V.V.(J)

SCHEMATIC 2

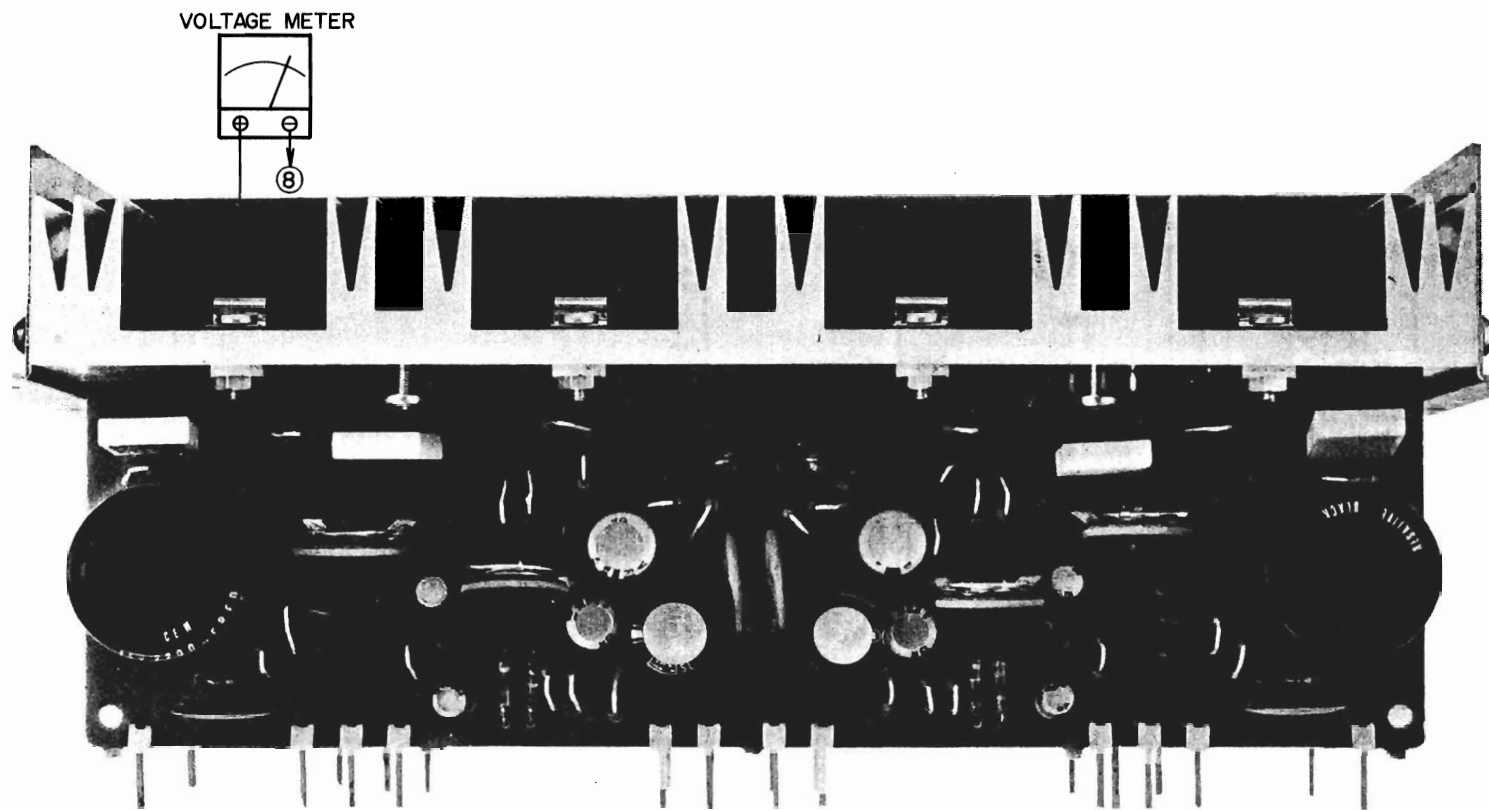

Fig. 19

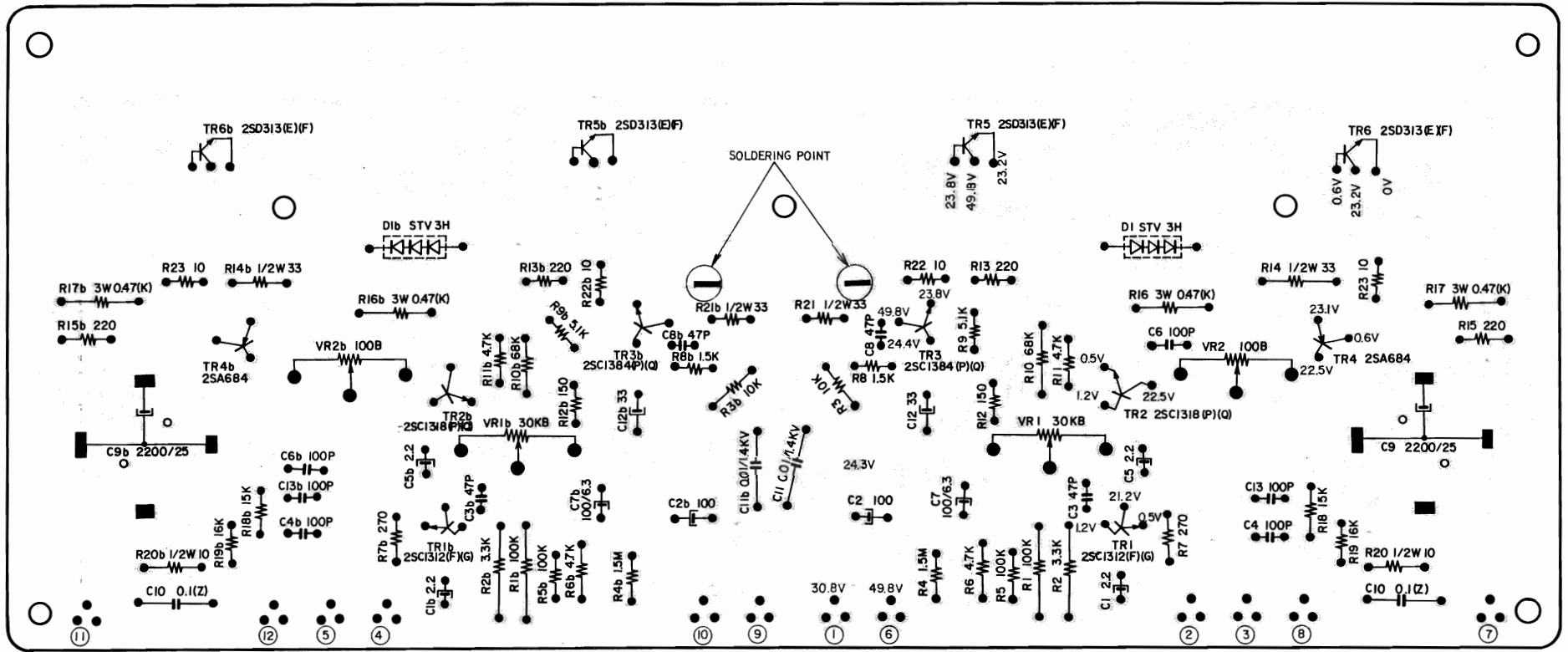
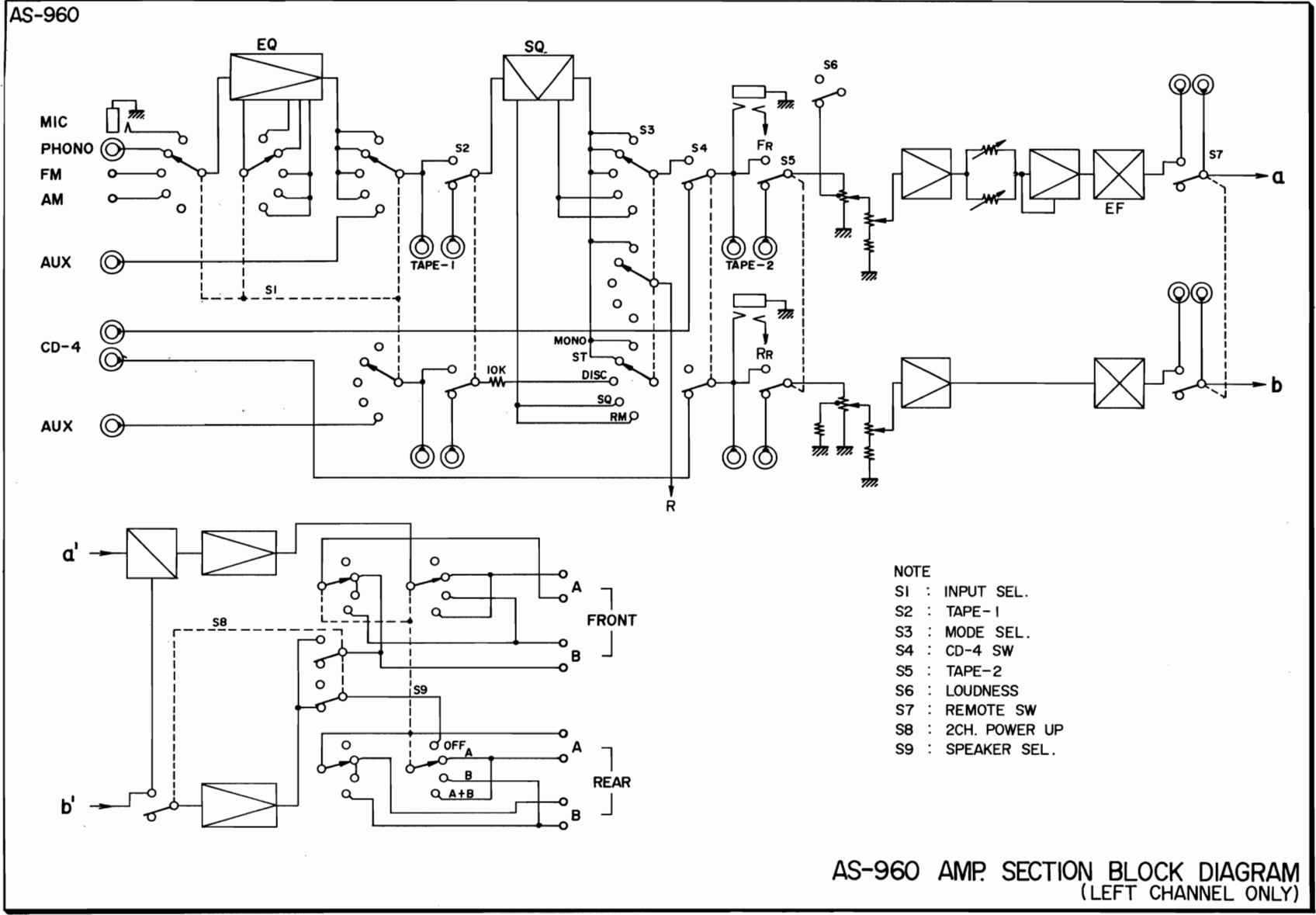

Fig. 20



AS-960 AMPLIFIER SECTION BLOCK DIAGRAM (Left Channel Only)

X. COMPOSITE VIEWS OF COMPONENTS

1. SQ P.C. BOARD 97-5010

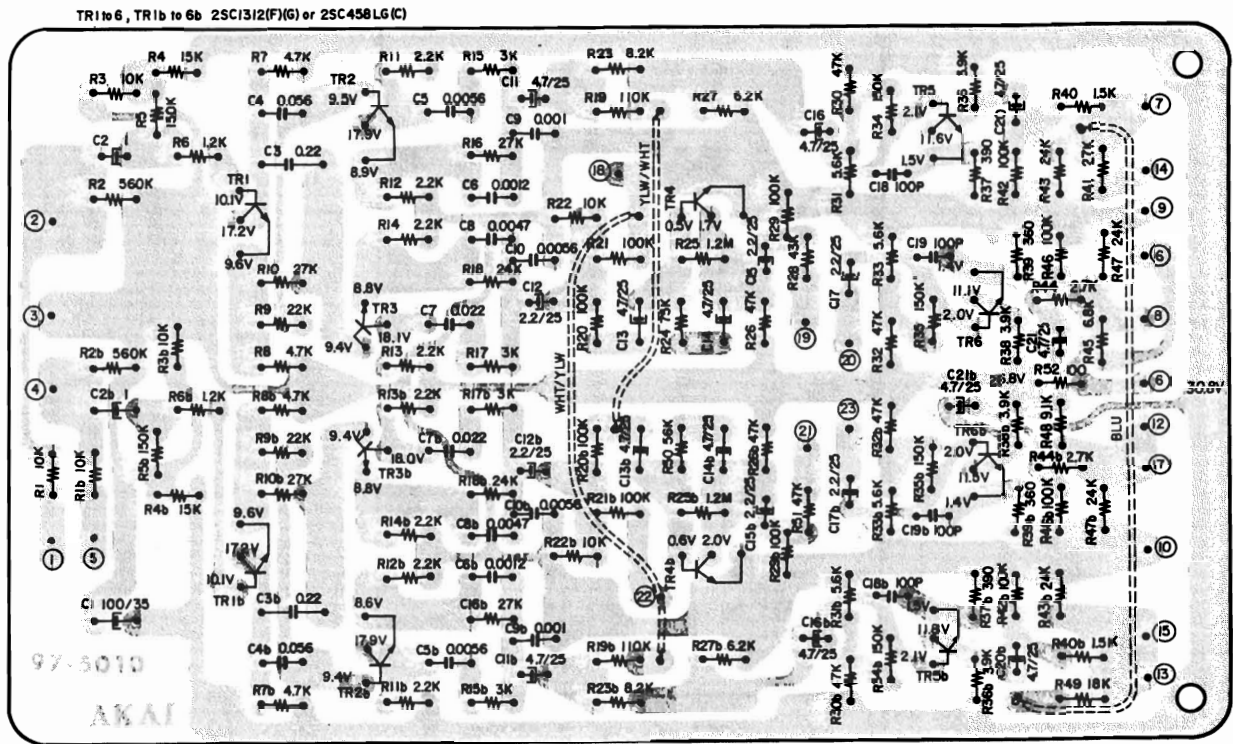

2. EQ AMP. P.C. BOARD 96-5004

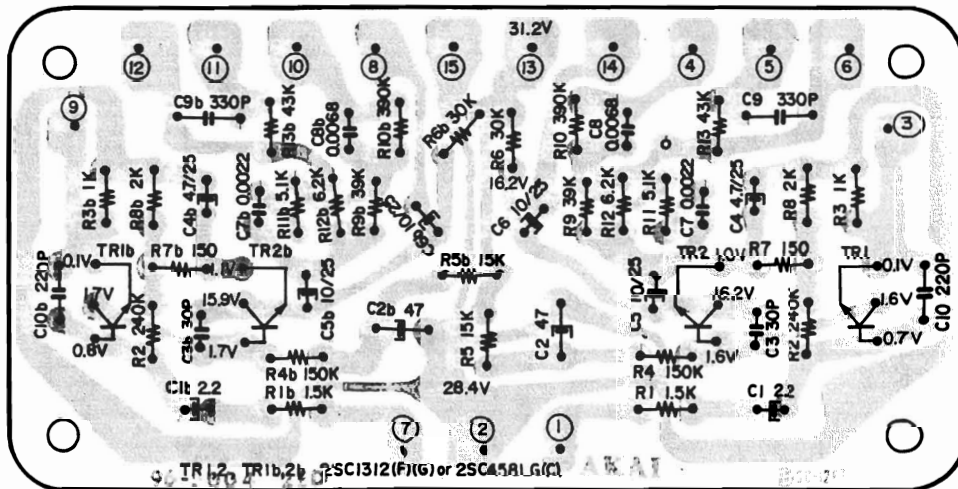

3. TAPE SW. P.C. BOARD 96-5001

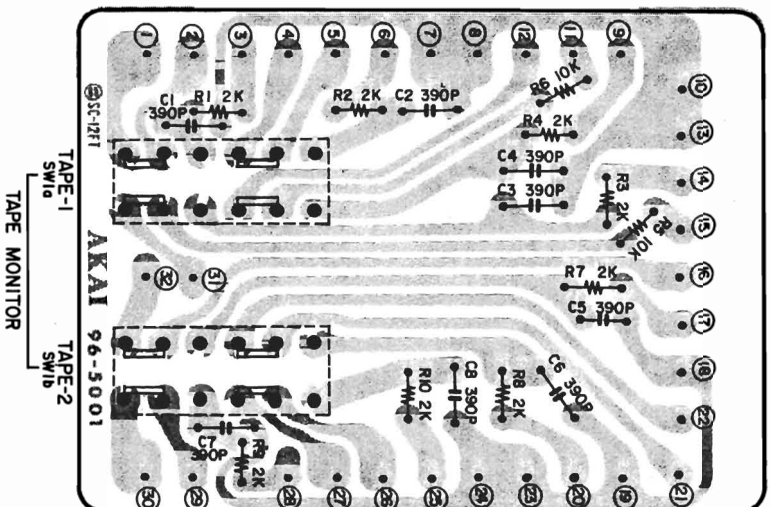

4. LOUDNESS SW. P.C. BOARD 96-5005

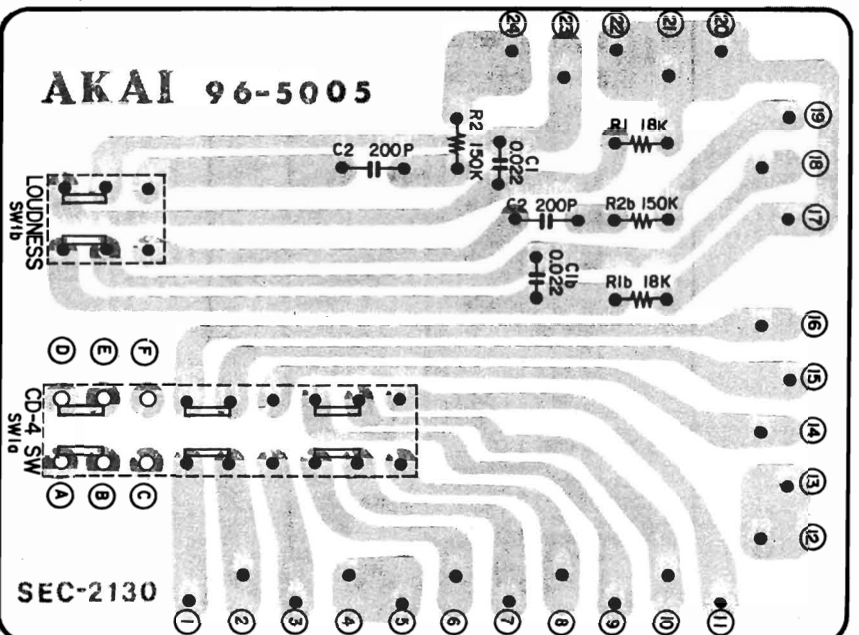

5. TONE CONTROL P.C. BOARD 96-5006

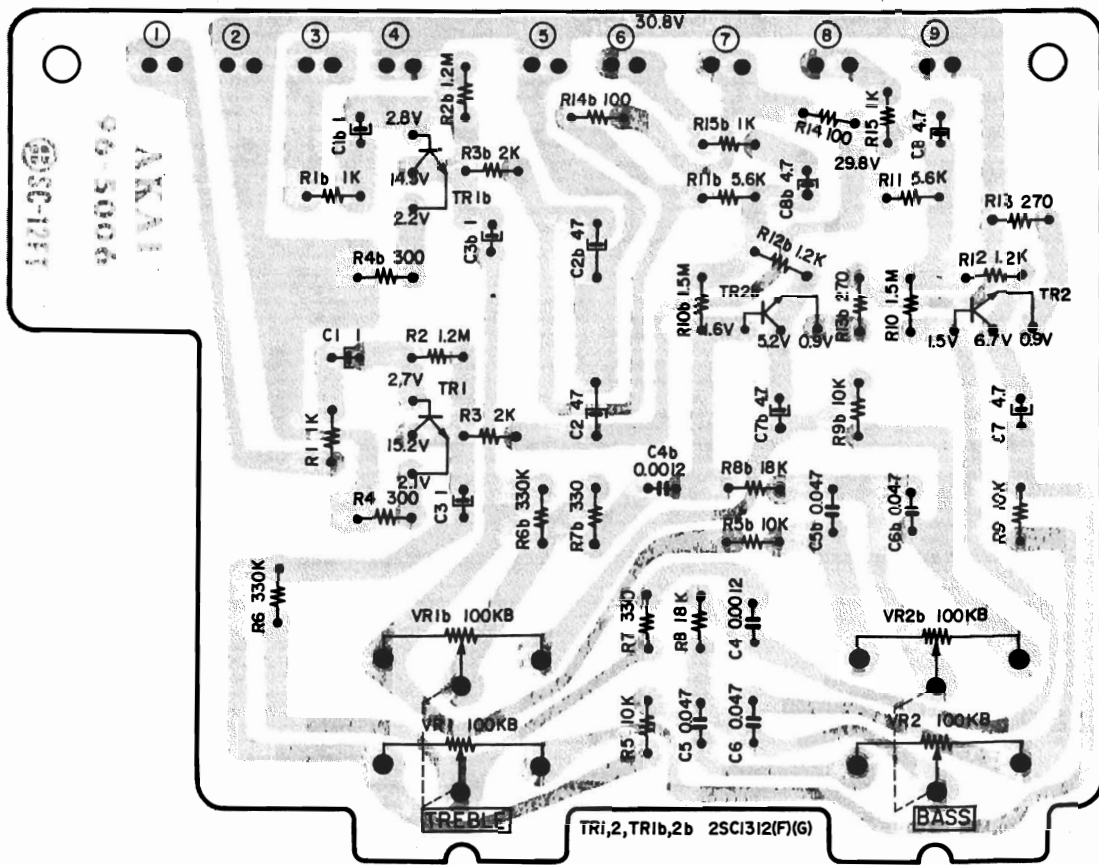

6. REMOTE SW. P.C. BOARD 96-5003

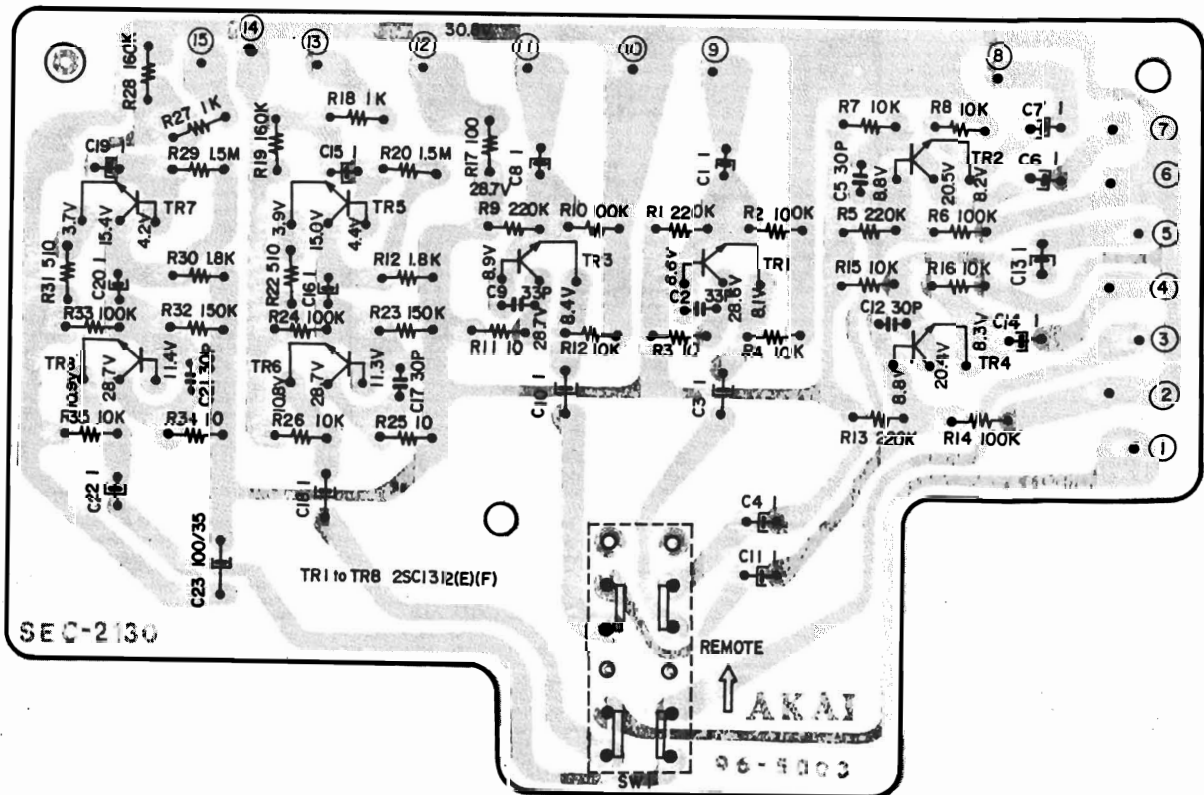

7. REGULATOR P.C. BOARD 98-5084

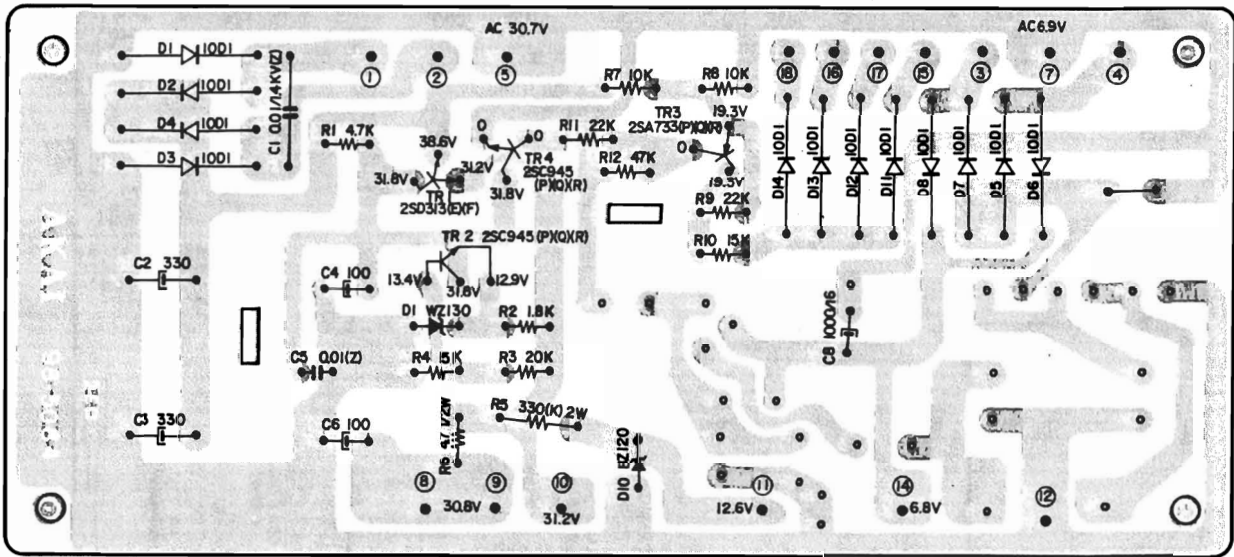

8. RECTIFIER P.C. BOARD (1) 98-5010

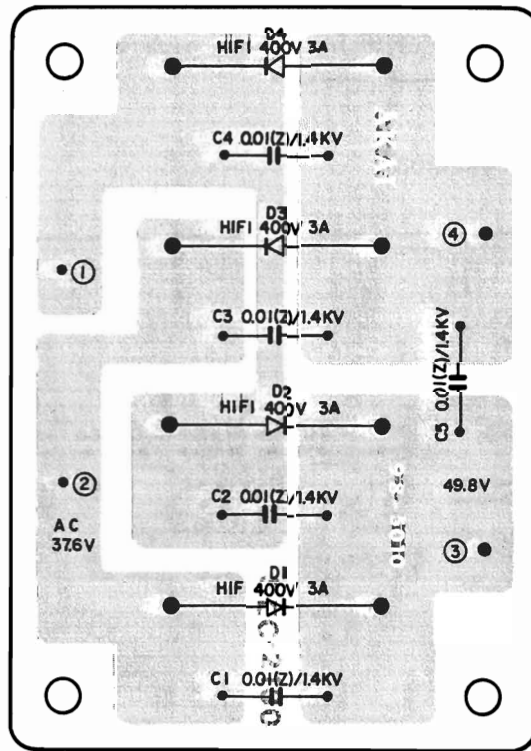

9. HEAD PHONE P.C. BOARD 98-5012

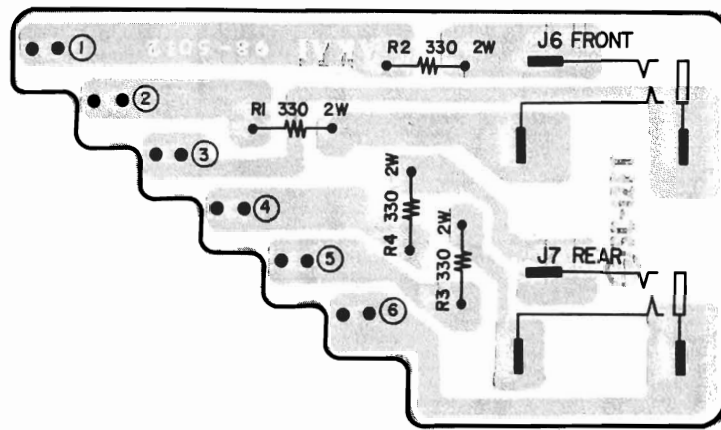

10. DUB P.C. BOARD 98-5013

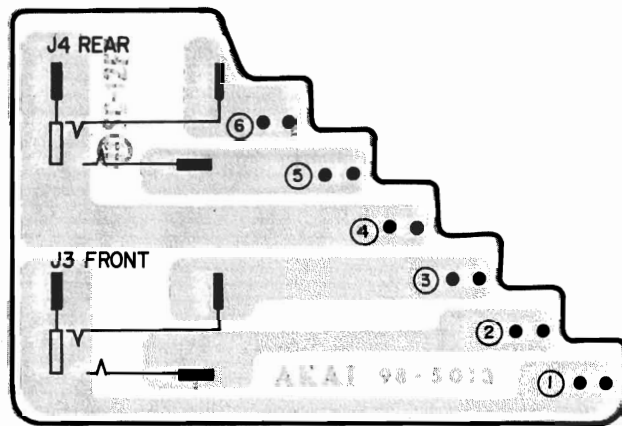

11. MIC P.C. BOARD 98-5059

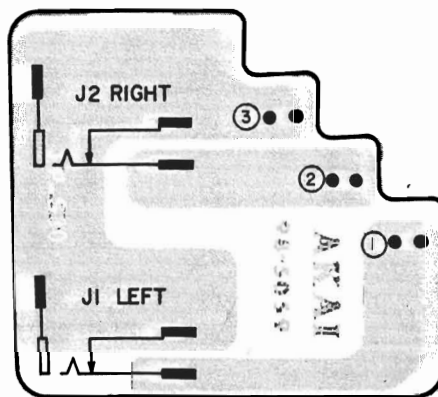

12. FRONT END P.C. BOARD 96-5007

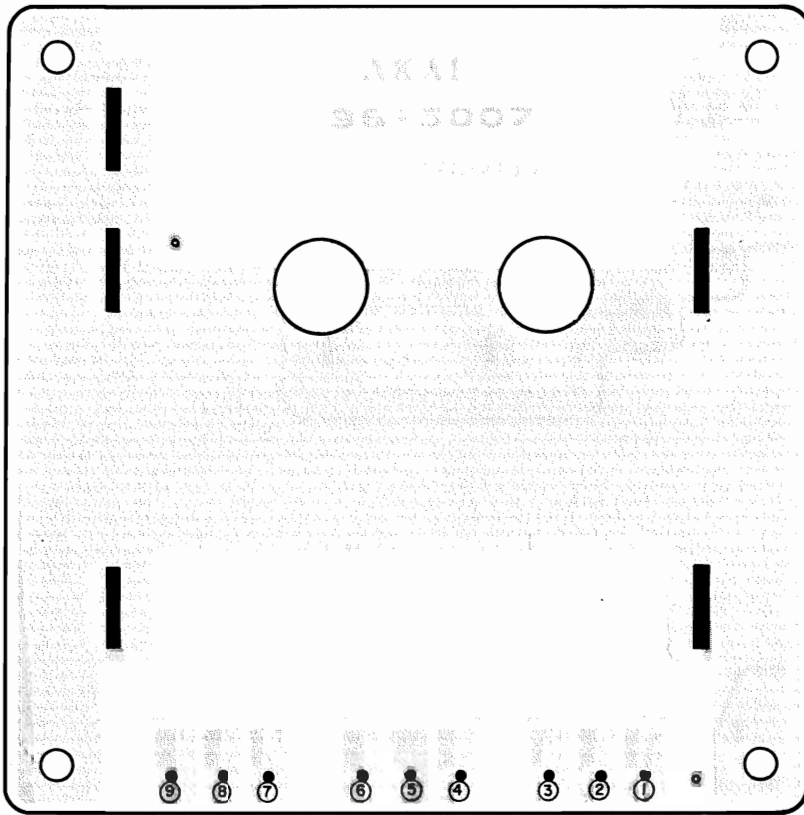

13. DIAL ILLUMINATION
P.C. BOARD 97-5008

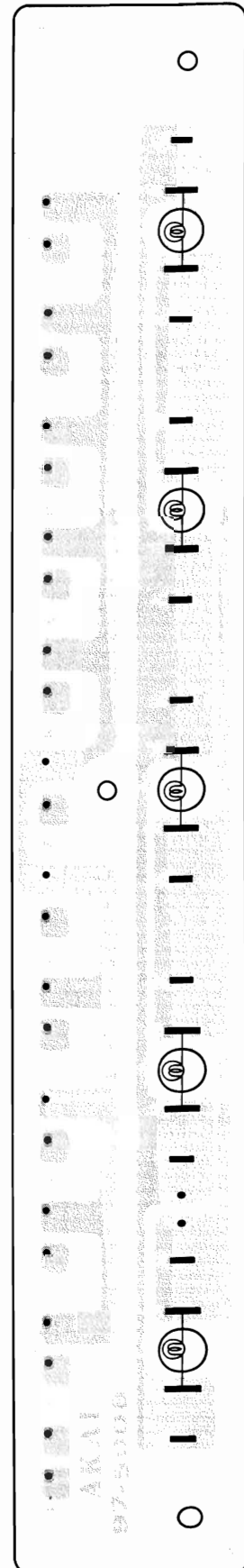

SECTION 2

PARTS LIST

TABLE OF CONTENTS

Fig. 1	IF P.C. BOARD (91-5033) BLOCK	36
Fig. 2	SQ P.C. BOARD (97-5010) BLOCK	38
Fig. 3	MAIN AMP. P.C. BOARD (96-5008) BLOCK	39
Fig. 4	EQ. P.C. BOARD (96-5004) BLOCK	40
Fig. 5	REGULATOR P.C. BOARD (98-5084) BLOCK	41
Fig. 6	RECTIFIER P.C. BOARD (98-5010) BLOCK	42
Fig. 7	TONE P.C. BOARD (96-5006) BLOCK	43
Fig. 8	REMOTE P.C. BOARD (96-5003) BLOCK	44
Fig. 9	MIC, DUB P.C. BOARD (98-5059, 98-5013) BLOCK ...	45
Fig. 10	HP P.C. BOARD (98-5012) BLOCK	45
Fig. 11	LOUDNESS P.C. BOARD (96-5005) BLOCK	46
Fig. 12	TAPE P.C. BOARD (96-5001) BLOCK	46
Fig. 13	LAMP P.C. BOARD (97-5008) BLOCK	47
Fig. 14	FRONT CHASSIS/REAR PANEL BLOCK	48
Fig. 15	ASSEMBLY BLOCK	50
Fig. 16	FINAL ASSEMBLY BLOCK	52
INDEX	53

HOW TO USE THIS PARTS LIST

1. This parts list is compiled by various individual blocks based on assembly process.
2. When ordering parts, please describe parts number, serial number, and model number in detail.
3. How to read list.

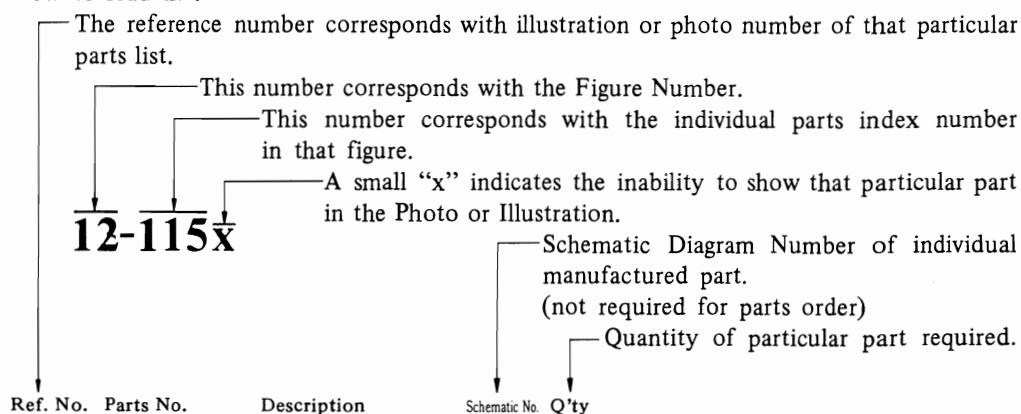

FLYWHEEL BLOCK #13

12-115x	800425	Flywheel Block Assy. Comp.	RDG #13	1
12-116	244506	Flywheel Only	RD-233	1
12-117x	244754	Felt, Flywheel	RD-275	1
12-118	251324	Main Metal Case	RD-236	1
12-119	253080	Main Metal	RD-237	1

4. The symbol numbers shown on the P.C. Board list can be matched with the Composite Views of components of the Schematic Diagram or Service Manual.
5. The indications of Resistors and Capacitors in the photos of P.C. Board are being eliminated.
6. The shape of the parts and parts name, etc. can be confirmed by comparing them with the parts shown on the Electrical Parts Table of P.C. Board.
7. Both the kind of part and installation position can be determined by the Parts Number. To determine where a parts number is listed, utilize Parts Index at end of Parts List.
It is necessary first of all to find the Parts Number. This can be accomplished by using the Reference Number listed at right of parts number in the Parts Index. (meaning of ref. no. outlined in Item 3 above).
8. Utilize separate "Price List for Parts" to determine unit price. The most simple method of finding parts Price is to utilize the reference number.

ELECTRICAL PARTS TABLE

<p>Because the indication of resistors and capacitors in the P. C. Board photos are being eliminated, please confirm parts name and shape by comparing them with the parts shown in this table.</p>	<p>1</p>  <p style="text-align: center;">Solid Resistor</p>	<p>2</p> <p style="text-align: right;">Stopper Type</p>  <p style="text-align: center;">Insulator Type Carbon Resistor</p>	<p>3</p>  <p style="text-align: center;">Metal Oxide Film Resistor</p>	
	<p>4</p>  <p style="text-align: center;">Cement Resistor</p>	<p>5</p>  <p style="text-align: center;">Wire-Wound Resistor</p>	<p>6</p>  <p style="text-align: center;">Thermister</p>	<p>7</p>  <p style="text-align: center;">Enamel Resistor</p>
	<p>1</p>  <p style="text-align: center;">MP Capacitor (Tubular Type)</p>	<p>2</p>  <p style="text-align: center;">Plastic Capacitor</p>	<p>3</p>  <p style="text-align: center;">Mylar Capacitor</p>	<p>4</p>  <p style="text-align: center;">VFM (Hi-Q) Capacitor</p>
	<p>5</p>  <p style="text-align: center;">Mylar Capacitor</p>	<p>6</p>  <p style="text-align: center;">Tantalum Capacitor</p>	<p>7</p>  <p style="text-align: center;">Oil Capacitor (Tubular Type)</p>	<p>8</p> <p style="text-align: right;">Vertical Type</p>  <p style="text-align: center;">Tubular Type Styrol Capacitor</p>
<p>9</p>  <p style="text-align: center;">Electrolytic Capacitor (Tubular Type)</p>	<p>10</p> <p style="text-align: right;">Vertical Type</p>  <p style="text-align: center;">Tubular Type Electrolytic Capacitor</p>	<p>11</p>  <p style="text-align: center;">Ceramic Capacitor</p>	<p>12</p>  <p style="text-align: center;">Metalized Mylar (Paper) Capacitor</p>	
<p>13</p>  <p style="text-align: center;">Trimmer Condenser</p>		<p>VR</p>  <p style="text-align: center;">Semi-Fixed Volume</p>		
<p>L</p>  <p style="text-align: center;">Ferri Inductor</p>	<p>TR</p>  <p style="text-align: center;">Transistor</p>			
<p>CR</p>  <p style="text-align: center;">Spark Quencher</p>	<p>D</p>  <p style="text-align: center;">Diode (Silicon, Zener, Germanium)</p>			

FIG. 1 PHOTO OF IF P.C. BOARD (91-5033) BLOCK

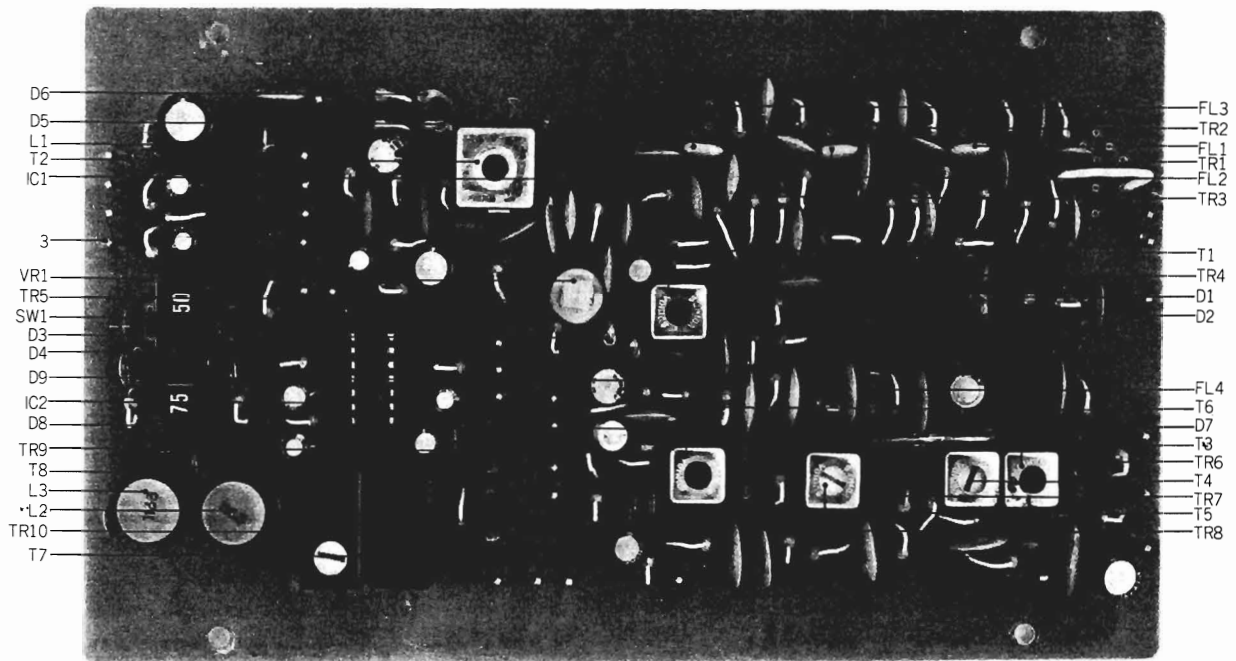

When ordering parts, please describe Parts Number, Serial Number, and Model Number in detail.

IF P.C. BOARD (91-5033) BLOCK

Symbol No.	Parts No.	Description	Q'ty	Symbol No.	Parts No.	Description	Q'ty
1-1x	BA563106	IF P.C. Board Comp. (91-5033)	1			Resistor, Stopper Type	
1-2x	BA563861	IF P.C. Board Comp. (91-5033) (US-B)	1	1-R1	ER361528	Carbon RD1/4 56k(J)	1
1-IC1	EI485291	I.C TA-7061AP	1	1-R2	ER349907	Carbon RD1/4 33k(J)	1
1-IC2	EI443744	I.C LA-3300	1	1-R3	ER212883	Carbon RD1/4 4.7k(J)	1
1-TR1 to 4	ET554016	Transistor 2SC839 (F) (H)	4	1-R4	ER363644	Carbon RD1/4 560(J)	1
1-TR5	ET510693	Transistor 2SC922 (L) (M)	1	1-R5	ER211667	Carbon RD1/4 100(J)	1
1-TR6 to 8	ET591366	Transistor 2SC454 (B) (C)	3	1-R6	ER380711	Carbon RD1/4 220k(J)	1
1-TR9, 10	ET398711	Transistor 2SC945 (Q) (R)	2	1-R7	ER213120	Carbon RD1/4 56(J)	1
1-D1 to 6	ED428264	Germanium Diode 1N60	6	1-R9	ER336442	Carbon RD1/4 10k(J)	1
1-D7 to 9	ED219464	Germanium Diode 1N34A	3	1-R10	ER212477	Carbon RD1/4 3.3k(J)	1
1-FL1 to 3	ER539818	Filter SFE-10.7MA5	3	1-R11	ER212681	Carbon RD1/4 330(J)	1
1-FL4	ER380406	Filter BFB 455B-5	1	1-R12	ER211465	Carbon RD1/4 1k(J)	1
1-FL4	ER380417	Filter BFB 464-A (US-B)	1	1-R13	ER211667	Carbon RD1/4 100(J)	1
1-T1	EO443700	Coil 05M-755 (Green) (10.7MHz)	1	1-R14	ER212681	Carbon RD1/4 330(J)	1
1-T2	EO537232	Discr Coil 05M-1376	1	1-R15	ER336442	Carbon RD1/4 10k(J)	1
1-T3	BT427915	AM OSC. Trans. ET-OSC	1	1-R16	ER212477	Carbon RD1/4 3.3k(J)	1
1-T4	BT379991	Trans. HI-137S (Yellow)	1	1-R17	ER212681	Carbon RD1/4 330(J)	1
1-T5	BT380384	Trans. HI-134S (White)	1	1-R18	ER211465	Carbon RD1/4 1k(J)	1
1-T6	BT443610	Trans. HI-144S (Black)	1	1-R19	ER211667	Carbon RD1/4 100(J)	1
1-T7	EO443766	Coil (19KC) 02-1070-03 1070 (Black)	1	1-R20	ER212681	Carbon RD1/4 330(J)	1
1-T8	EO443777	Coil (38KC) 02-1064-03 1064 (White)	1	1-R21	ER336442	Carbon RD1/4 10k(J)	1
1-L1	EO539820	Peaking Coil 2.2μH(K)	1	1-R22	ER212477	Carbon RD1/4 3.3k(J)	1
1-L2, 3	EO445788	Choke Coil 7-1133-02 L=40MH	2	1-R23	ER212681	Carbon RD1/4 330(J)	1
1-VR1	EV539831	Semi-fixed/Vol. SR19R-68 kH (Solid Type)	1	1-R24	ER211465	Carbon RD1/4 1k(J)	1
1-SW1	ES513922	Slide SW. SSB02242	1	1-R26	ER357412	Carbon RD1/4 220(J)	1
1-3	EJ539662	Wrapping Post 1x17	28	1-R27	ER211667	Carbon RD1/4 100(J)	1
		Capacitor, Vertical Type		1-R28	ER212681	Carbon RD1/4 330(J)	1
1-C2 to 25	EC404256	Ceramic DD610YM 0.015μF (Z) 50WV	24	1-R29	ER211667	Carbon RD1/4 100(J)	1
1-C26 to 34	EC492142	Ceramic DD512YM 0.047μF (Z) 50WV	9	1-R30, 31	ER211465	Carbon RD1/4 1k(J)	2
1-C35	EC443654	VFM 15PF(K) 50WV	1	1-R32	ER211667	Carbon RD1/4 100(J)	1
1-C36	EC357827	VFM 50PF(K) 50WV	1	1-R33 to 35	ER336442	Carbon RD1/4 10k(J)	3
1-C37	EC350706	Elect. 4.7μF 16WV	1	1-R36	ER349828	Carbon RD1/4 20k(J)	1
1-C40	EC290531	VFM 100PF(K) 50WV	1	1-R37	ER304290	Carbon RD1/4 10(J)	1
1-C41, 42	EC320040	Elect. 4.7μF 16WV	2	1-R38	ER346601	Carbon RD1/4 47k(J)	1
1-C43, 44	EC539842	VFM 200PF(K) 50WV	2	1-R39	ER349942	Carbon RD1/4 8.2k(J)	1
1-C45	EC220994	Elect. 10μF 25WV	1	1-R40	ER211667	Carbon RD1/4 100(J)	1
1-C46	EC290531	VFM 100PF(K) 50WV	1	1-R41	ER357456	Carbon RD1/4 2.2k(J)	1
1-C47	EC320051	Elect. 10μF 16WV	1	1-R42	ER306843	Carbon RD1/4 1.2k(J)	1
1-C48	EC250885	Mylar 0.01μF(K) 50WV	1	1-R43	ER211667	Carbon RD1/4 100(J)	1
1-C49	EC427937	VFM 360PF(J) 50WV	1	1-R44	ER361528	Carbon RD1/4 56k(J)	1
1-C50	EC419231	VFM 12PF(J) 50WV	1	1-R45	ER211465	Carbon RD1/4 1k(J)	1
1-C51	EC220994	Elect. 10μF 25WV	1	1-R46	ER211320	Carbon RD1/4 1.5k(J)	1
1-C52	EC331705	Elect. 22μF 16WV	1	1-R47	ER211667	Carbon RD1/4 100(J)	1
1-C53, 54	EC250885	Mylar 0.01μF(K) 50WV	2	1-R48	ER357535	Carbon RD1/4 39k(J)	1
1-C55	EC220994	Elect. 10μF 25WV	1	1-R49	ER336442	Carbon RD1/4 10k(J)	1
1-C56	EC432808	Elect. 0.47μF 50WV NL	1	1-R50	ER304402	Carbon RD1/4 470(J)	1
1-C57	EC321208	Elect. 220μF 16WV	1	1-R51	ER211465	Carbon RD1/4 1k(J)	1
1-C58	EC350706	Elect. 4.7μF 16WV	1	1-R52	ER211667	Carbon RD1/4 100(J)	1
1-C59	EC250661	Mylar 0.0015μF(K) 50WV	1	1-R53	ER213030	Carbon RD1/4 5.6k(J)	1
1-C60 to 62	EC350706	Elect. 4.7μF 16WV	3	1-R54	ER211465	Carbon RD1/4 1k(J)	1
1-C63, 64	EC362158	Mylar 0.0047μF(K) 50WV	2	1-R55	ER304402	Carbon RD1/4 470(J)	1
1-C65, 66	EC350875	Mylar 0.001μF(J) 50WV	2	1-R56	ER213030	Carbon RD1/4 5.6k(J)	1
1-C67, 68	EC342821	Mylar 0.0068μF(K) 50WV	2	1-R57	ER212681	Carbon RD1/4 330(J)	1
1-C69, 70	EC390633	Mylar 0.0027μF(K) 50WV	2	1-R58	ER211667	Carbon RD1/4 100(J)	1
1-C71, 72	EC250964	Mylar 0.012μF(K) 50WV	2	1-R59	ER420232	Carbon RD1/4 7.5k(J)	1
1-C73, 74	EC350706	Elect. 4.7μF 16WV	2	1-R60	ER304402	Carbon RD1/4 470(J)	1
				1-R61	ER304290	Carbon RD1/4 10(J)	1
				1-R62, 63	ER343078	Carbon RD1/4 2.7k(J)	2
				1-R64, 65	ER357456	Carbon RD1/4 2.2k(J)	2
				1-R66	ER306887	Carbon RD1/4 15k(J)	1
				1-R67	ER213030	Carbon RD1/4 5.6k(J)	1
				1-R68	ER357456	Carbon RD1/4 2.2k(J)	1
				1-R69	ER306887	Carbon RD1/4 15k(J)	1
				1-R70	ER213030	Carbon RD1/4 5.6k(J)	1
				1-R71	ER212681	Carbon RD1/4 330(J)	1

When ordering parts, please describe Parts Number, Serial Number, and Model Number in detail.

FIG. 2 PHOTO OF SQ P.C. BOARD (97-5010) BLOCK

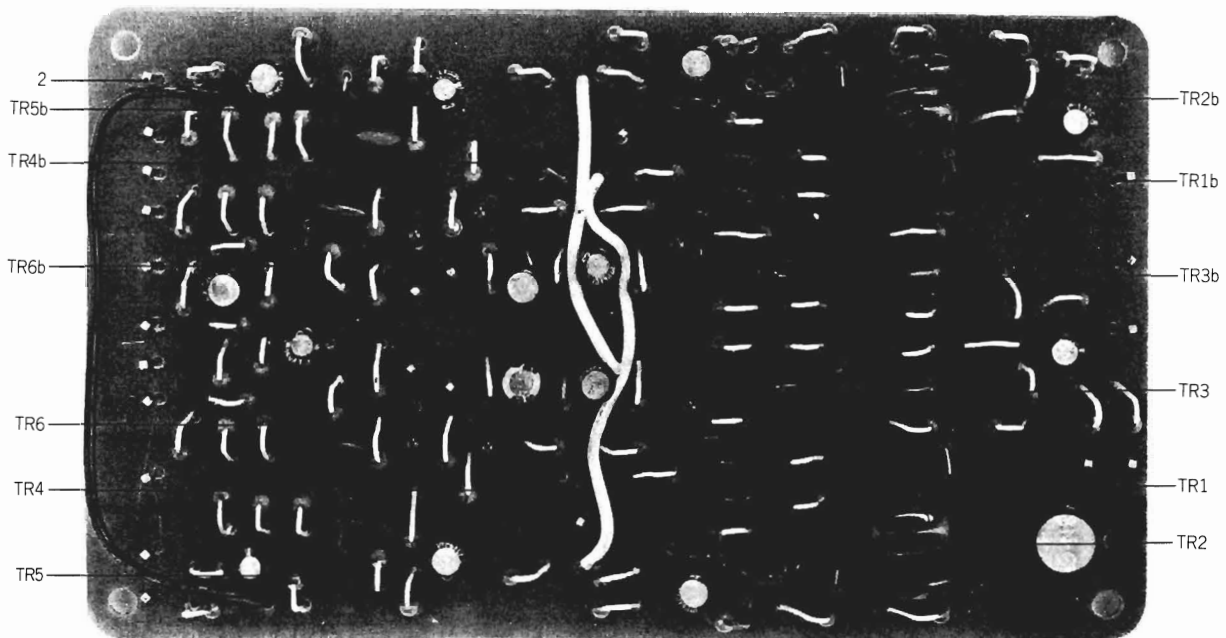

SQ P.C. BOARD (97-5010) BLOCK

Symbol No.	Parts No.	Description	Q'ty	Symbol No.	Parts No.	Description	Q'ty
2-1x	BA562342	SQ P.C. Board Comp. (97-5010)	1	2-R17	ER346544	Carbon RD1/4 3k(J)	2
2-TR1 to 6	ET539987	Transistor 2SC1312 (F) (G)	12	2-R18	ER407316	Carbon RD1/4 24k(J)	2
2-2	EJ539662	Wrapping Post 1x17	22	2-R19	ER379552	Carbon RD1/4 110k(J)	2
Capacitor, Vertical Type				2-R20, 21	ER211757	Carbon RD1/4 100k(J)	4
2-C1	EC455354	Elect. 100μF 35WV	1	2-R22	ER336442	Carbon RD1/4 10k(J)	2
2-C2	EC313108	Elect. 1μF 50WV	2	2-R23	ER349942	Carbon RD1/4 8.2k(J)	2
2-C3	EC538435	Mylar 0.22μF(J) 50WV	2	2-R24	ER362520	Carbon RD1/4 75k(J)	1
2-C4	EC368357	Mylar 0.056μF(J) 50WV	2	2-R25	ER423753	Carbon RD1/4 1.2M(J)	2
2-C5	EC329883	Mylar 0.0056μF(J) 50WV	2	2-R26	ER346601	Carbon RD1/4 47k(J)	2
2-C6	EC379721	Mylar 0.0012μF(J) 50WV	2	2-R27	ER380755	Carbon RD1/4 6.2k(J)	2
2-C7	EC368335	Mylar 0.022μF(J) 50WV	2	2-R28	ER419556	Carbon RD1/4 43k(J)	1
2-C8	EC337500	Mylar 0.0047μF(J) 50WV	2	2-R29	ER211757	Carbon RD1/4 100k(J)	2
2-C9	EC350875	Mylar 0.001μF(J) 50WV	2	2-R30	ER346601	Carbon RD1/4 47k(J)	2
2-C10	EC329883	Mylar 0.0056μF(J) 50WV	2	2-R31	ER213030	Carbon RD1/4 5.6k(J)	2
2-C11	EC450527	Elect. 4.7μF 25WV	2	2-R32	ER346601	Carbon RD1/4 47k(J)	2
2-C12	EC522551	Tantalum 2.2μF(M) 25WV (DTS Type)	2	2-R33	ER213030	Carbon RD1/4 5.6k(J)	2
2-C13, 14	EC450527	Elect. 4.7μF 25WV	4	2-R34, 35	ER357570	Carbon RD1/4 150k(J)	4
2-C15	EC522551	Tantalum 2.2μF(M) 25WV (DTS Type)	2	2-R36	ER352045	Carbon RD1/4 3.9k(J)	2
2-C16	EC450527	Elect. 4.7μF 25WV	2	2-R37	ER349784	Carbon RD1/4 390(J)	2
2-C17	EC522551	Tantalum 2.2μF(M) 25WV (DTS Type)	2	2-R38	ER352045	Carbon RD1/4 3.9k(J)	2
2-C18, 19	EC290520	VFM 100PF(J) 50WV	4	2-R39	ER381723	Carbon RD1/4 360(J)	2
2-C20, 21	EC450527	Elect. 4.7μF 25WV	4	2-R40	ER211320	Carbon RD1/4 1.5k(J)	2
Resistor, Stopper Type				2-R41	ER342933	Carbon RD1/4 27k(J)	1
2-R1	ER336442	Carbon RD1/4 10k(J)	2	2-R42	ER211757	Carbon RD1/4 100k(J)	2
2-R2	ER430086	Carbon RD1/4 560k(J)	2	2-R43	ER407316	Carbon RD1/4 24k(J)	2
2-R3	ER336442	Carbon RD1/4 10k(J)	2	2-R44	ER343078	Carbon RD1/4 2.7k(J)	2
2-R4	ER306887	Carbon RD1/4 15k(J)	2	2-R45	ER306360	Carbon RD1/4 6.8k(J)	1
2-R5	ER357570	Carbon RD1/4 150k(J)	2	2-R46	ER211757	Carbon RD1/4 100k(J)	2
2-R6	ER306843	Carbon RD1/4 1.2k(J)	2	2-R47	ER407316	Carbon RD1/4 24k(J)	2
2-R7, 8	ER212883	Carbon RD1/4 4.7k(J)	4	2-R48	ER399060	Carbon RD1/4 9.1k(J)	1
2-R9	ER212264	Carbon RD1/4 22k(J)	2	2-R49	ER346994	Carbon RD1/4 18k(J)	1
2-R10	ER342933	Carbon RD1/4 27k(J)	2	2-R50	ER361528	Carbon RD1/4 56k(J)	1
2-R11 to 14	ER357456	Carbon RD1/4 2.2k(J)	8	2-R51	ER346601	Carbon RD1/4 47k(J)	1
2-R15	ER346544	Carbon RD1/4 3k(J)	4	2-R52	ER211667	Carbon RD1/4 100(J)	1
2-R16	ER342933	Carbon RD1/4 27k(J)	2				

When ordering parts, please describe Parts Number, Serial Number, and Model Number in detail.

FIG. 3 PHOTO OF MAIN AMP. P.C. BOARD (96-5008) BLOCK

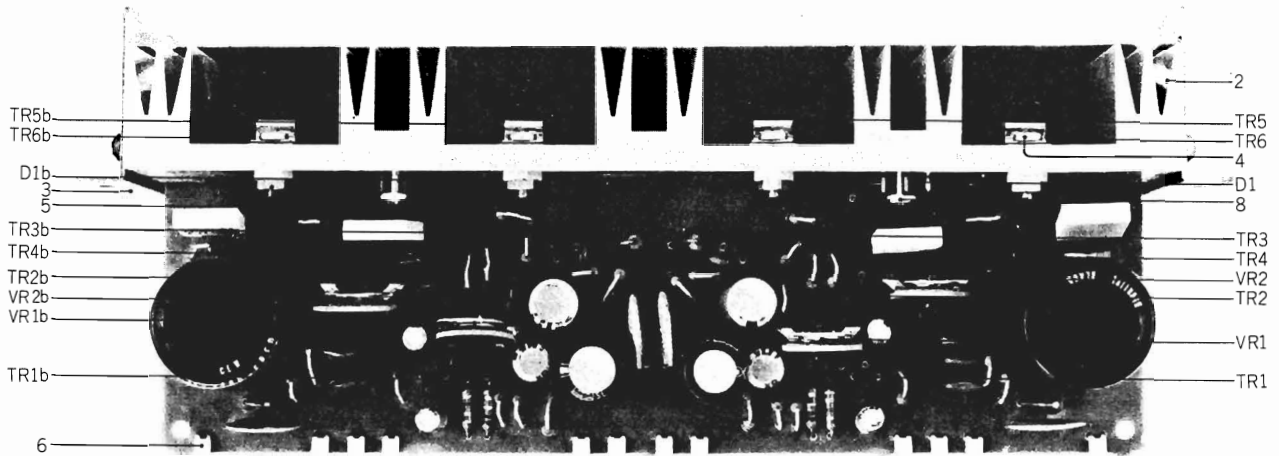

MAIN AMP. P.C. BOARD (96-5008) BLOCK

Symbol No.	Parts No.	Description	Q'ty	Symbol No.	Parts No.	Description	Q'ty
3-1x	BA570914	Main Amp. P.C. Board Comp. (96-5008)	1	Resistor, Stopper Type			
3-TR1	ET539987	Transistor 2SC1312 (F) (G)	2	3-R1	ER213715	Carbon RD1/4 100k(J) (Insu. Type)	2
3-TR2, 3, 4	ET562858	Transistor 2SC1318 (P) (Q)	6	3-R2	ER364948	Carbon RD1/4 3.3k(J) (Insu. Type)	2
3-TR5, 6	ET452531	Transistor 2SD313 (E) (F)	4	3-R3	ER336442	Carbon RD1/4 10k(J)	2
3-D1	ED556514	Varistor STV-3H	2	3-R4	ER430007	Carbon RD1/4 1.5M(J)	2
3-VR1	EV383398	Semi-fixed/Vol. V18k3-2 30 kB (4US)	2	3-R5	ER211757	Carbon RD1/4 100k(J)	2
3-VR2	EV409858	Semi-fixed/Vol. V18k3-2 100B (4US)	2	3-R6	ER212883	Carbon RD1/4 4.7k(J)	2
3-2	EZ548234	Heat-sink Plate	1	3-R7	ER347038	Carbon RD1/4 270(J)	2
3-3	AZ562836	Heat-sink Holder RH-14	4	3-R8	ER211320	Carbon RD1/4 1.5k(J)	2
3-4	ZS450832	ISO Screw, binding head 3x12	4	3-R9	ER324202	Carbon RD1/4 5.1k(J)	2
3-5	ZW348107	ISO Nut M3	4	3-R10	ER350100	Carbon RD1/4 68k(J)	2
3-6	EJ550012	Wrapping Terminal T5280	12	3-R11	ER212883	Carbon RD1/4 4.7k(J)	2
3-7x	ZW426622	Washer (SPC) D3.4x7.8x0.5t	2	3-R12	ER212016	Carbon RD1/4 150(J)	2
3-8	ZS321298	ISO Screw, binding head 3x8	3	3-R13	ER357412	Carbon RD1/4 220(J)	2
		Capacitor, Vertical Type		3-R14	ER380913	Carbon RD1/4 33(J)	2
3-C1	EC354947	Elect. 2.2μF 50WV	2	3-R15	ER357412	Carbon RD1/4 220(J)	2
3-C2	EC321221	Elect. 100μF 50WV	2	3-R16, 17	ER556064	Metal Plate MPC71F2 5W 0.47 (K)	4
3-C3	EC377212	VFM 47PF(J) 50WV	2	3-R18	ER306887	Carbon RD1/4 15k(J)	2
3-C4	EC290520	VFM 100PF(J) 50WV	2	3-R19	ER379596	Carbon RD1/4 16k(J)	2
3-C5	EC354947	Elect. 2.2μF 50WV	2	3-R20	ER452542	Carbon RD1/2 10(J)(Insu. Type)	2
3-C6	EC290520	VFM 100PF(J) 50WV	2	3-R21	ER556795	Carbon RD1/2 33(J)(Insu. Type)	2
3-C7	EC336104	Elect. 100μF 6.3WV	2	3-R22, 23	ER304290	Carbon RD1/4 10(J)	4
3-C8	EC377212	VFM 47PF(J) 50WV	2				
3-C9	EC562847	Elect. 2200μF 25WV (Lug Type)	2				
3-C10	EC228745	Ceramic DB209YZ 0.1μF(Z) 50WV	2				
3-C11	EC551160	Ceramic NB821YZ 0.01μF(Z) 1.4kWV	2				
3-C12	EC373296	Elect. 33μF 50WV	2				
3-C13	EC290520	VFM 100PF(J) 50WV	2				

When ordering parts, please describe Parts Number, Serial Number, and Model Number in detail.

FIG. 4 PHOTO OF EQ. P.C. BOARD (96-5004) BLOCK

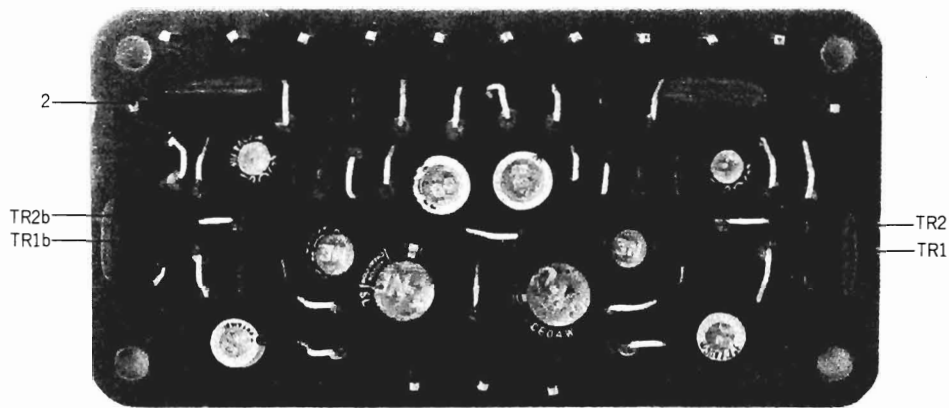

EQ. P.C. BOARD (96-5004) BLOCK

Symbol No.	Parts No.	Description	Q'ty
4-1x	BA563117	EQ. P.C. Board Comp. (96-5004)	1
4-TR1, 2	ET539987	Transistor 2SC1312 (F) (G)	4
4-2	EJ539662	Wrapping Post 1x17	15
Capacitor, Vertical Type			
4-C1	EC483142	Elect. 2.2 μ F 50WV NL	2
4-C2	EC346735	Elect. 47 μ F 50WV	2
4-C3	EC476324	VFM 30PF(J) 50WV	2
4-C4	EC450527	Elect. 4.7 μ F 25WV	2
4-C5	EC220994	Elect. 10 μ F 25WV	2
4-C6	EC517138	Elect. 10 μ F 25WV NL	2
4-C7	EC250683	Mylar 0.0022 μ F(J) 50WV	2
4-C8	EC380621	Mylar 0.0068 μ F(J) 50WV	2
4-C9	EC336216	VFM 330PF(J) 50WV	2
4-C10	EC329850	VFM 220PF(J) 50WV	2
Resistor, Stopper Type			
4-R1	ER211320	Carbon RD1/4 1.5k(J)	2
4-R2	ER443878	Carbon RD1/4 240k(J)	2
4-R3	ER211465	Carbon RD1/4 1k(J)	2
4-R4	ER357570	Carbon RD1/4 150k(J)	2
4-R5	ER306887	Carbon RD1/4 15k(J)	2
4-R6	ER379473	Carbon RD1/4 30k(J)	2
4-R7	ER212016	Carbon RD1/4 150(J)	2
4-R8	ER371946	Carbon RD1/4 2k(J)	2
4-R9	ER357535	Carbon RD1/4 39k(J)	2
4-R10	ER392850	Carbon RD1/4 390k(J)	2
4-R11	ER324202	Carbon RD1/4 5.1k(J)	2
4-R12	ER380755	Carbon RD1/4 6.2k(J)	2
4-R13	ER419556	Carbon RD1/4 43k(J)	2

When ordering parts, please describe Parts Number, Serial Number, and Model Number in detail.

FIG. 5 PHOTO OF REGULATOR P.C. BOARD (98-5084) BLOCK

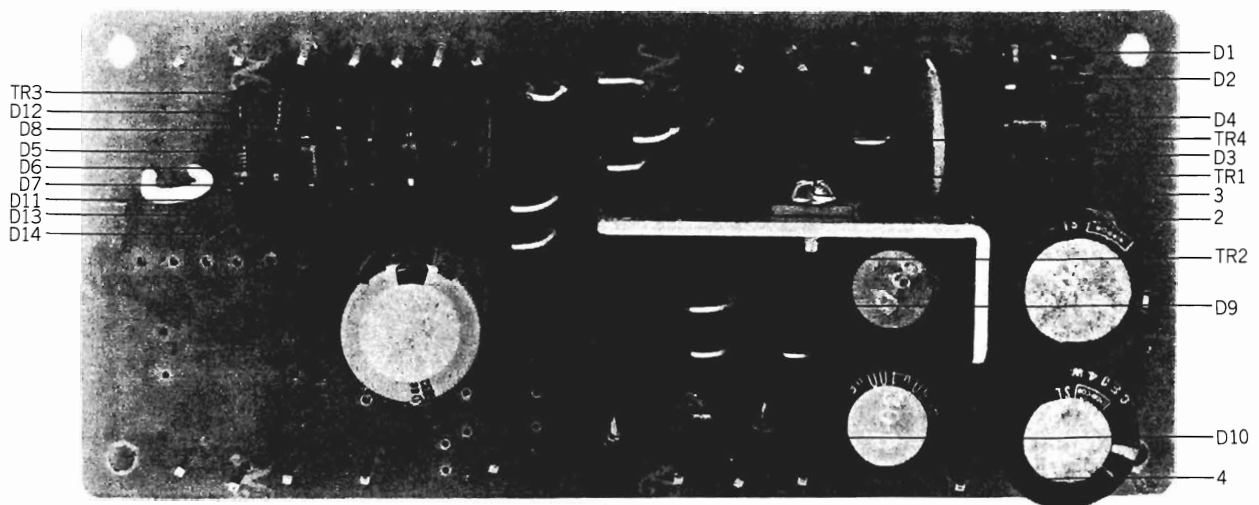

REGULATOR P.C. BOARD (98-5084) BLOCK

Symbol No.	Parts No.	Description	Q'ty
5-1x	BA570407	Regulator P.C. Board Comp. (98-5084)	1
5-TR1	ET557998	Transistor 2SC313 (E) (F)	1
5-TR2	ET517994	Transistor 2SC945(P)(Q)(R)(K)	1
5-TR3	ET539122	Transistor 2SA733(P)(Q)(R)	1
5-TR4	ET517994	Transistor 2SC945(P)(Q)(R)(K)	1
5-D1 to 8	ED224526	Silicon Diode 10D1	8
5-D9	ED539976	Zener Diode WZ-130	1
5-D10	ED562814	Zener Diode BZ-120	1
5-D11 to 14	ED224526	Silicon Diode 10D1	4
5-2	AA545117	Heat-sink	1
5-3	ZS447772	Tapping Screw #2 3x6 (BR)	1
5-4	EJ539662	Wrapping Post 1x17	19
5-5x	EJ558022	Hookup Terminal (T Type)	5
		T-4410	
		Capacitor, Vertical Type	
5-C1	EC551160	Ceramic NB821 YZ 0.01 μ F (Z) 1.4kVW	1
5-C2, 3	EC403468	Elect. 330 μ F 50WV	2
5-C4	EC321221	Elect. 100 μ F 50WV	1
5-C5	EC557627	Ceramic DB203 YZ 0.01 μ F (Z) 50WV	1
5-C6	EC321221	Elect. 100 μ F 50WV	1
5-C7	EC220127	Elect. 100 μ F 16WV	1
5-C8	EC336148	Elect. 1000 μ F 16WV	1
		Resistor, Stopper Type	
5-R1	ER212883	Carbon RD1/4 4.7k(J)	1
5-R2	ER362441	Carbon RD1/4 1.8k(J)	1
5-R3	ER349828	Carbon RD1/4 20k(J)	1
5-R4	ER306887	Carbon RD1/4 15k(J)	1
5-R5	ER559034	Metal Oxide Film 2W 330(K)	1
5-R6	ER536984	Carbon RD1/2 4.7 (J) (Insu. Type)	1
5-R7, 8	ER336442	Carbon RD1/4 10k(J)	2
5-R9	ER212264	Carbon RD1/4 22k(J)	2
5-R10	ER306887	Carbon RD1/4 15k(J)	1
5-R11	ER212264	Carbon RD1/4 22k(J)	2
5-R12	ER346601	Carbon RD1/4 47k(J)	1

When ordering parts, please describe Parts Number, Serial Number, and Model Number in detail.

FIG. 6 PHOTO OF RECTIFIER P.C. BOARD (98-5010) BLOCK

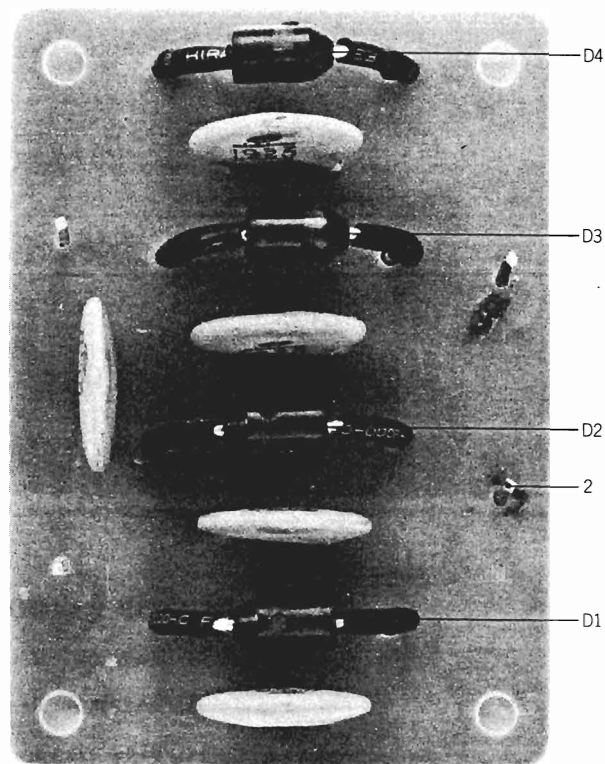

RECTIFIER P.C. BOARD (98-5010) BLOCK

Symbol No.	Parts No.	Description	Q'ty
6-1x	BA560676	Rectifier P.C. Board Comp. (98-5010)	1
6-D1 to 4	ED558033	Silicon Diode HIF1 400V 3A (Special)	4
6-2	EJ539662	Wrapping Post 1x17	4
6-C1 to 5	EC551160	Ceramic/C. NB821YZ 0.01 μ F(Z) 1.4kWV	5

When ordering parts, please describe Parts Number, Serial Number, and Model Number in detail.

FIG. 7 PHOTO OF TONE P.C. BOARD (96-5006) BLOCK

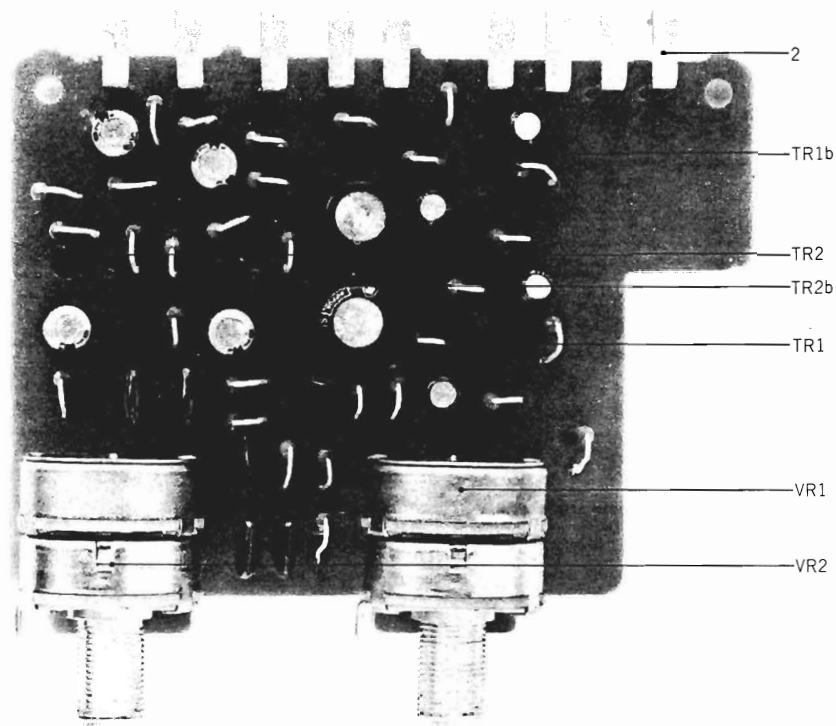

TONE P.C. BOARD (96-5006) BLOCK

Symbol No.	Parts No.	Description	Q'ty
7-1x	BA562994	Tone P.C. Board Comp. (96-5006)	1
7-TR1, 2	ET539987	Transistor 2SC1312 (F) (G)	4
7-VR1, 2	EV555941	Co-axial 2-throw Vol. (w/click) V24L5GPHN 100kΩx2 1 kB	2
7-2	EJ539673	Wrapping Terminal T5290	9
Capacitor, Vertical Type			
7-C1	EC338501	Elect. 1μF 50WV	2
7-C2	EC346206	Elect. 47μF 50WV	2
7-C3	EC338501	Elect. 1μF 50WV	2
7-C4	EC379721	Mylar 0.0012μF(J) 50WV	2
7-C5, 6	EC379214	Mylar 0.047μF(J) 50WV	4
7-C7, 8	EC346590	Elect. 4.7μF 50WV	4
Resistor, Stopper Type			
7-R1	ER211465	Carbon RD1/4 1k(J)	2
7-R2	ER423753	Carbon RD1/4 1.2M(J)	2
7-R3	ER371946	Carbon RD1/4 2k(J)	2
7-R4	ER361607	Carbon RD1/4 300(J)	2
7-R5	ER336442	Carbon RD1/4 10k(J)	2
7-R6	ER362485	Carbon RD1/4 330k(J)	2
7-R7	ER212681	Carbon RD1/4 330(J)	2
7-R8	ER346994	Carbon RD1/4 18k(J)	2
7-R9	ER336442	Carbon RD1/4 10k(J)	2
7-R10	ER430007	Carbon RD1/4 1.5M(J)	2
7-R11	ER213030	Carbon RD1/4 5.6k(J)	2
7-R12	ER306843	Carbon RD1/4 1.2k(J)	2
7-R13	ER347038	Carbon RD1/4 270(J)	2
7-R14	ER211667	Carbon RD1/4 100(J)	2
7-R15	ER211465	Carbon RD1/4 1k(J)	2

When ordering parts, please describe Parts Number, Serial Number, and Model Number in detail.

FIG. 8 PHOTO OF REMOTE P.C. BOARD (96-5003) BLOCK

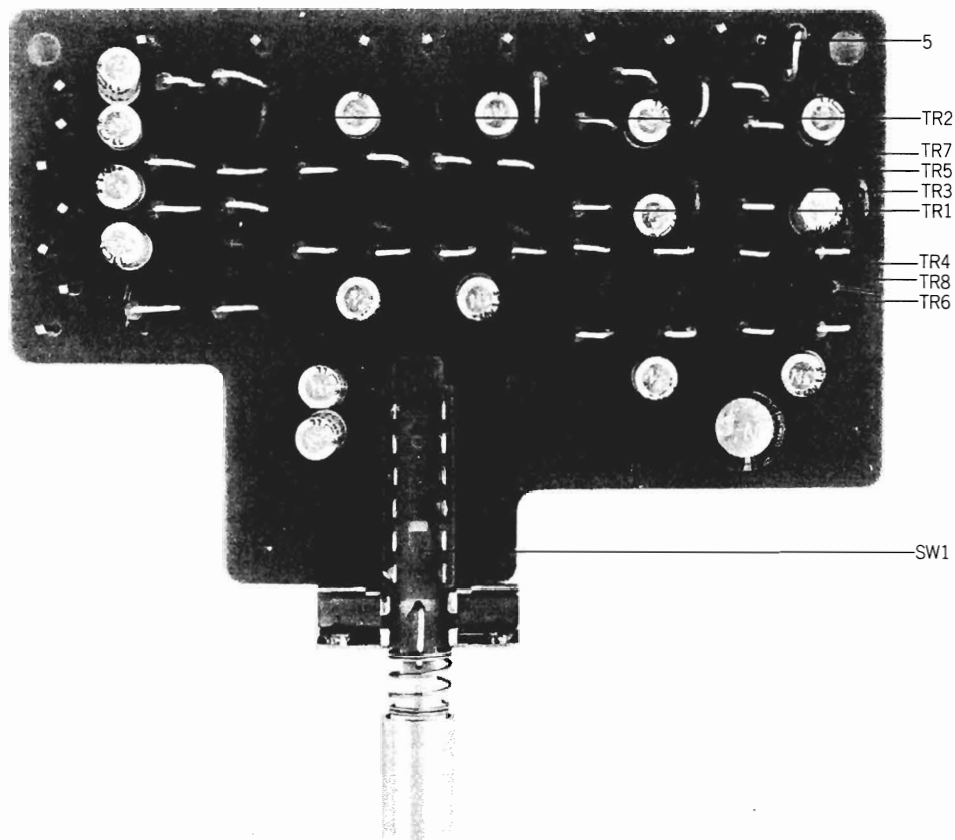

REMOTE P.C. BOARD (96-5003) BLOCK

Symbol No.	Parts No.	Description	Q'ty	Symbol No.	Parts No.	Description	Q'ty
8-1x	BA562983	Remote P.C. Board Comp. (96-5003)	1	Resistor, Stopper Type			
8-TR1 to 8	ET539987	Transistor 2SC1312 (F) (G)	8	8-R1	ER380711	Carbon RD1/4 220k(J)	1
8-SW1	ES562781	Push SW. 1FS-4U-8	1	8-R2	ER211757	Carbon RD1/4 100k(J)	1
8-J3	EJ557910	Socket CS289	1	8-R3	ER304290	Carbon RD1/4 10(J)	1
8-2x	ZS379405	ISO Screw, binding head 3x6	2	8-R4	ER336442	Carbon RD1/4 10k(J)	1
8-3x	ZS371856	ISO Screw, binding head 3x5	2	8-R5	ER380711	Carbon RD1/4 220k(J)	1
8-4x	AZ545534	Remote SW. Mt. Angle	1	8-R6	ER211757	Carbon RD1/4 100k(J)	1
8-5	EJ539662	Wrapping Post 1x17	15	8-R7, 8	ER336442	Carbon RD1/4 10k(J)	2
		Capacitor, Vertical Type		8-R9	ER380711	Carbon RD1/4 220k(J)	1
8-C1	EC479621	Elect. 1μF 50WV NL	1	8-R10	ER211757	Carbon RD1/4 100k(J)	1
8-C2	EC399690	VFM 33PF(J) 50WV	1	8-R11	ER304290	Carbon RD1/4 10(J)	1
8-C3, 4	EC479621	Elect. 1μF 50WV NL	2	8-R12	ER336442	Carbon RD1/4 10k(J)	1
8-C5	EC476324	VFM 30PF(J) 50WV	1	8-R13	ER380711	Carbon RD1/4 220k(J)	1
8-C6, 7, 8	EC479621	Elect. 1μF 50WV NL	3	8-R14	ER211757	Carbon RD1/4 100k(J)	1
8-C9	EC399690	VFM 33PF(J) 50WV	1	8-R15, 16	ER336442	Carbon RD1/4 10k(J)	2
8-C10, 11	EC479621	Elect. 1μF 50WV NL	2	8-R17	ER211667	Carbon RD1/4 100(J)	1
8-C12	EC476324	VFM 30PF(J) 50WV	1	8-R18	ER211465	Carbon RD1/4 1k(J)	1
8-C13 to 16	EC479621	Elect. 1μF 50WV NL	4	8-R19	ER404087	Carbon RD1/4 160k(J)	1
8-C17	EC476324	VFM 30PF(J) 50WV	1	8-R20	ER430007	Carbon RD1/4 1.5M(J)	1
8-C18 to 20	EC479621	Elect. 1μF 50WV NL	3	8-R21	ER362441	Carbon RD1/4 1.8k(J)	1
8-C21	EC476324	VFM 30PF(J) 50WV	1	8-R22	ER213096	Carbon RD1/4 510(J)	1
8-C22	EC479621	Elect. 1μF 50WV NL	1	8-R23	ER357570	Carbon RD1/4 150k(J)	1
8-C23	EC455354	Elect. 100μF 35WV	1	8-R24	ER211757	Carbon RD1/4 100k(J)	1
				8-R25	ER304290	Carbon RD1/4 10(J)	1
				8-R26	ER336442	Carbon RD1/4 10k(J)	1
				8-R27	ER211465	Carbon RD1/4 1k(J)	1
				8-R28	ER404087	Carbon RD1/4 160k(J)	1
				8-R29	ER430007	Carbon RD1/4 1.5M(J)	1
				8-R30	ER362441	Carbon RD1/4 1.8k(J)	1
				8-R31	ER213096	Carbon RD1/4 510(J)	1
				8-R32	ER357570	Carbon RD1/4 150k(J)	1
				8-R33	ER211757	Carbon RD1/4 100k(J)	1
				8-R34	ER304290	Carbon RD1/4 10(J)	1
				8-R35	ER336442	Carbon RD1/4 10k(J)	1

When ordering parts, please describe Parts Number, Serial Number, and Model Number in detail.

FIG. 9 PHOTO OF MIC, DUB P.C. BOARD (98-5059, 98-5013) BLOCK

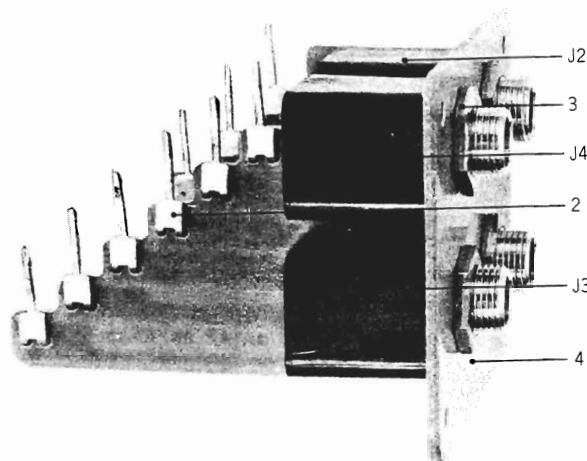

**MIC, DUB P.C. BOARD (98-5059, 98-5013)
BLOCK**

Symbol No.	Parts No.	Description	Q'ty
9-1x	BA563016	Mic, Dub P.C. Board Comp. (98-5059, 98-5013)	1
9-J1, 2	EJ391094	Mic. Jack 2PMJ1P	2
9-J3, 4	EJ391083	Mic. Jack 3PMJ1P	2
9-2	EJ550012	Wrapping Terminal T5280	9
9-3	ZW270191	E Jack Nut	4
9-4	AZ549112	Jack Mt. Plate	1

FIG. 10 PHOTO OF HP P.C. BOARD (98-5012) BLOCK

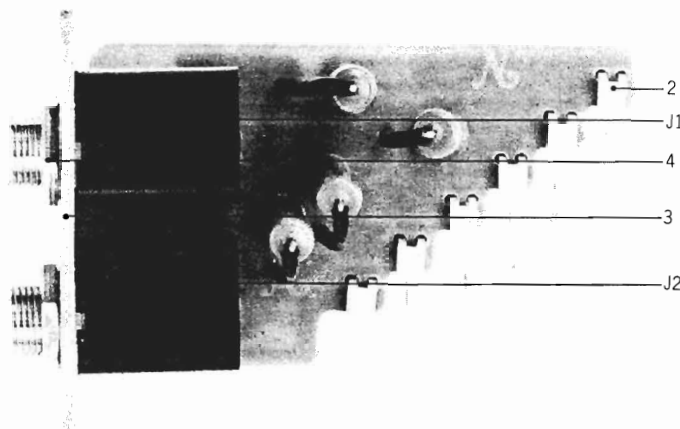

HP P.C. BOARD (98-5012) BLOCK

Symbol No.	Parts No.	Description	Q'ty
10-1x	BA560531	HP P.C. Board Comp. (98-5012)	1
10-J1, 2	EJ437321	Jack, 3P Molded 3PMJ1P	2
10-2	EJ550012	Wrapping Terminal T5280	6
10-3	AZ544836	Phone Jack Mt. Plate	1
10-4	ZW270191	E Jack Nut	2
10-R1 to 4	ER559034	Metal Oxide Film/R. 2W 3 30Ω (K)	4

When ordering parts, please describe Parts Number, Serial Number, and Model Number in detail.

FIG. 11 PHOTO OF LOUDNESS P.C. BOARD (96-5005) BLOCK

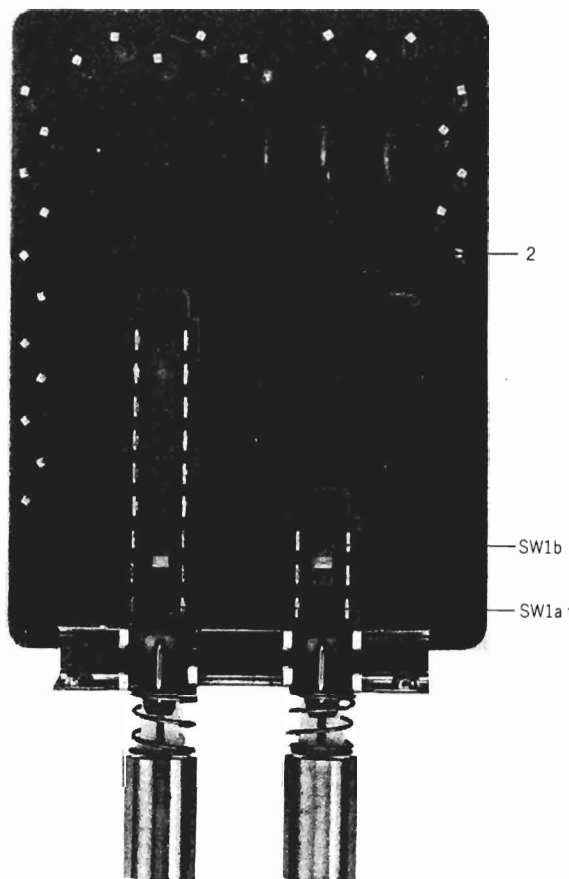
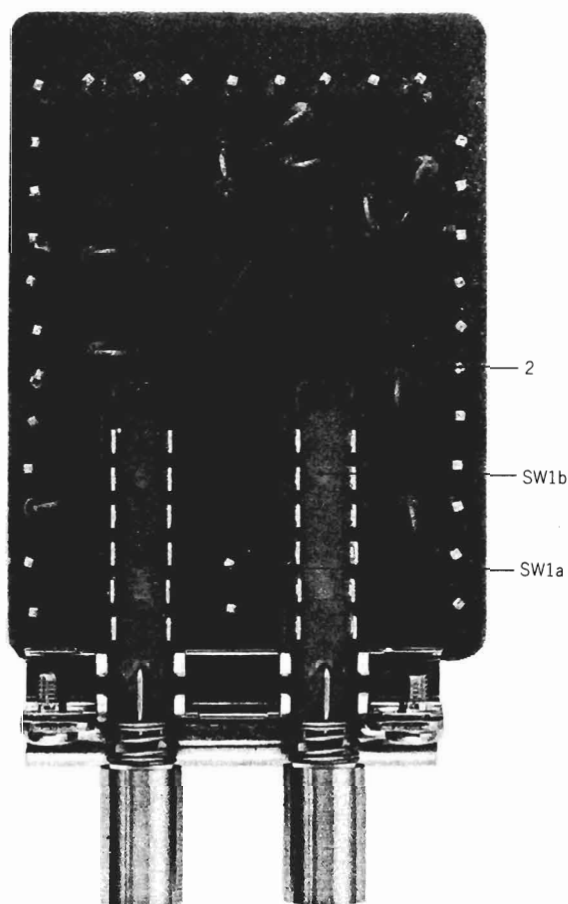

FIG. 12 PHOTO OF TAPE P.C. BOARD (96-5001) BLOCK



LOUDNESS P.C. BOARD (96-5005) BLOCK

Symbol No.	Parts No.	Description	Q'ty
11-1x	BA563005	Loudness P.C. Board Comp. (96-5005)	1
11-SW1	ES591131	Push SW. 2FT-0001 FF-2020	1
11-2	EJ539662	Wrapping Post 1x17	24
Capacitor, Vertical Type			
11-C1	EC368335	Mylar 0.022 μ F(J) 50WV	2
11-C2	EC389237	VFM 200PF(J) 50WV	2
Resistor, Stopper Type			
11-R1	ER346994	Carbon RD1/4 18k(J)	2
11-R2	ER357570	Carbon RD1/4 150k(J)	2

TAPE P.C. BOARD (96-5001) BLOCK

Symbol No.	Parts No.	Description	Q'ty
12-1x	BA563027	Tape P.C. Board Comp. (96-5001)	1
12-SW1	ES551272	Push SW. 2FS-8U-70	1
12-2	EJ539662	Wrapping Post 1x17	32
12-C1 to 8	EC557616	Ceramic/C. UFD06B 390PF(K) 50WV	8
Resistor, Stopper Type			
12-R1 to 8	ER371946	Carbon RD1/4 2k(J)	8
12-R9, 10	ER336442	Carbon RD1/4 10k(J)	2

When ordering parts, please describe Parts Number, Serial Number, and Model Number in detail.

**FIG. 13 PHOTO OF LAMP P.C. BOARD
(97-5008) BLOCK**

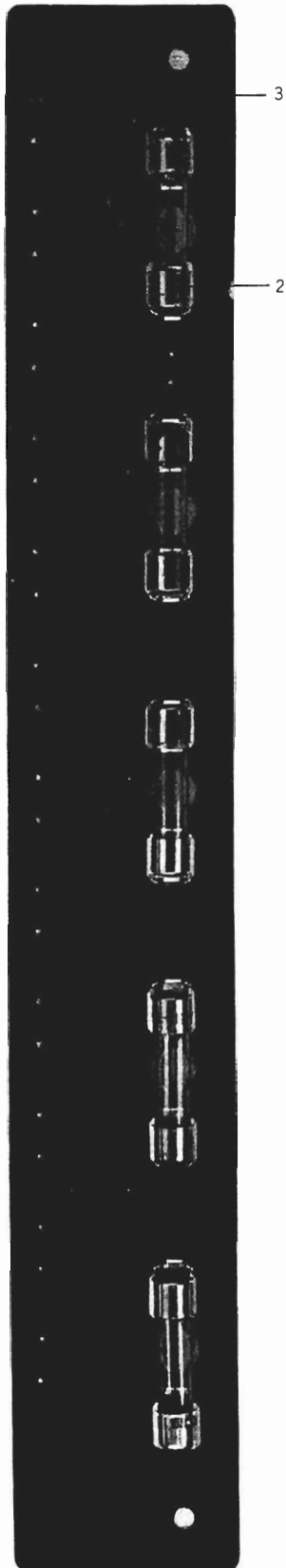

LAMP P.C. BOARD (97-5008) BLOCK

Symbol No.	Parts No.	Description	Q'ty
13-1x	BA562274	Lamp P.C. Board Comp. (97-5008)	1
13-2	EJ514822	Fuse Holder, P.C. Board S-N5051	10
13-3	EJ539662	Wrapping Post 1x17	17

When ordering parts, please describe Parts Number, Serial Number, and Model Number in detail.

FIG. 14 PHOTO OF FRONT CHASSIS/REAR PANEL BLOCK

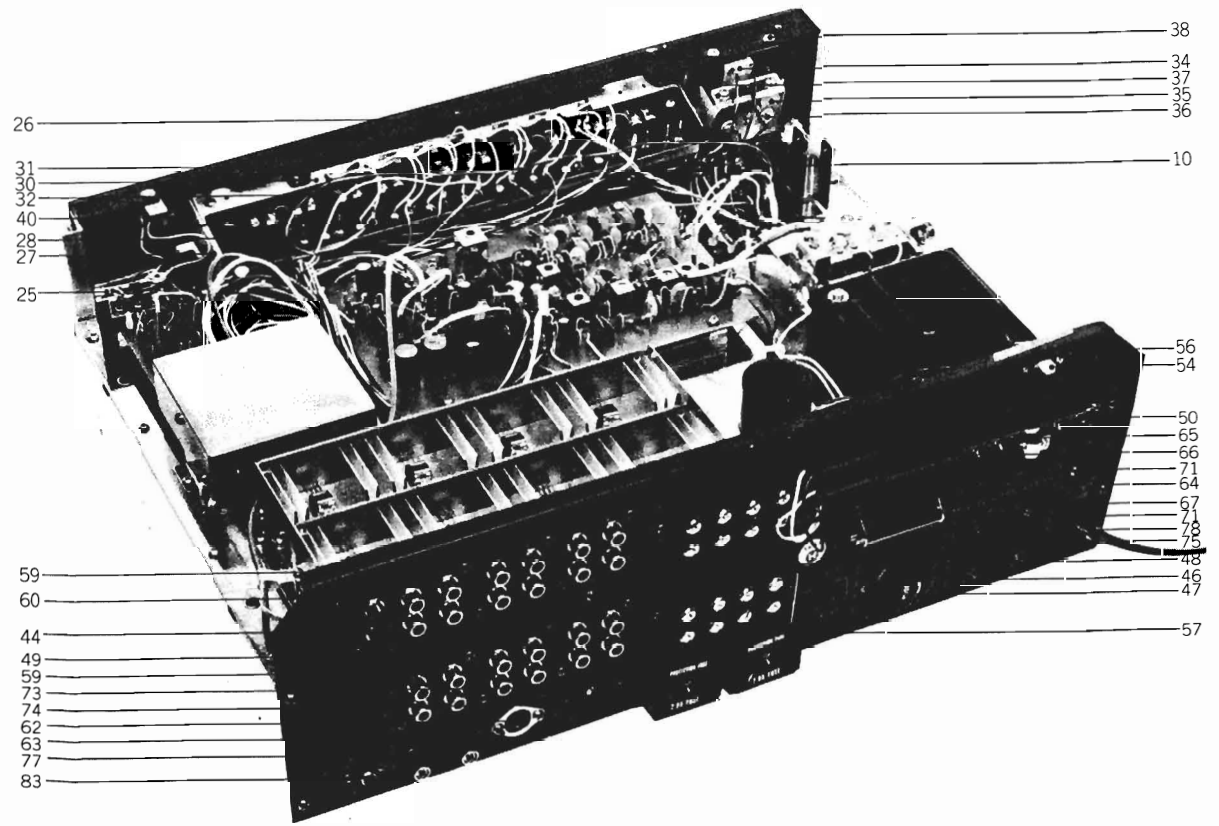
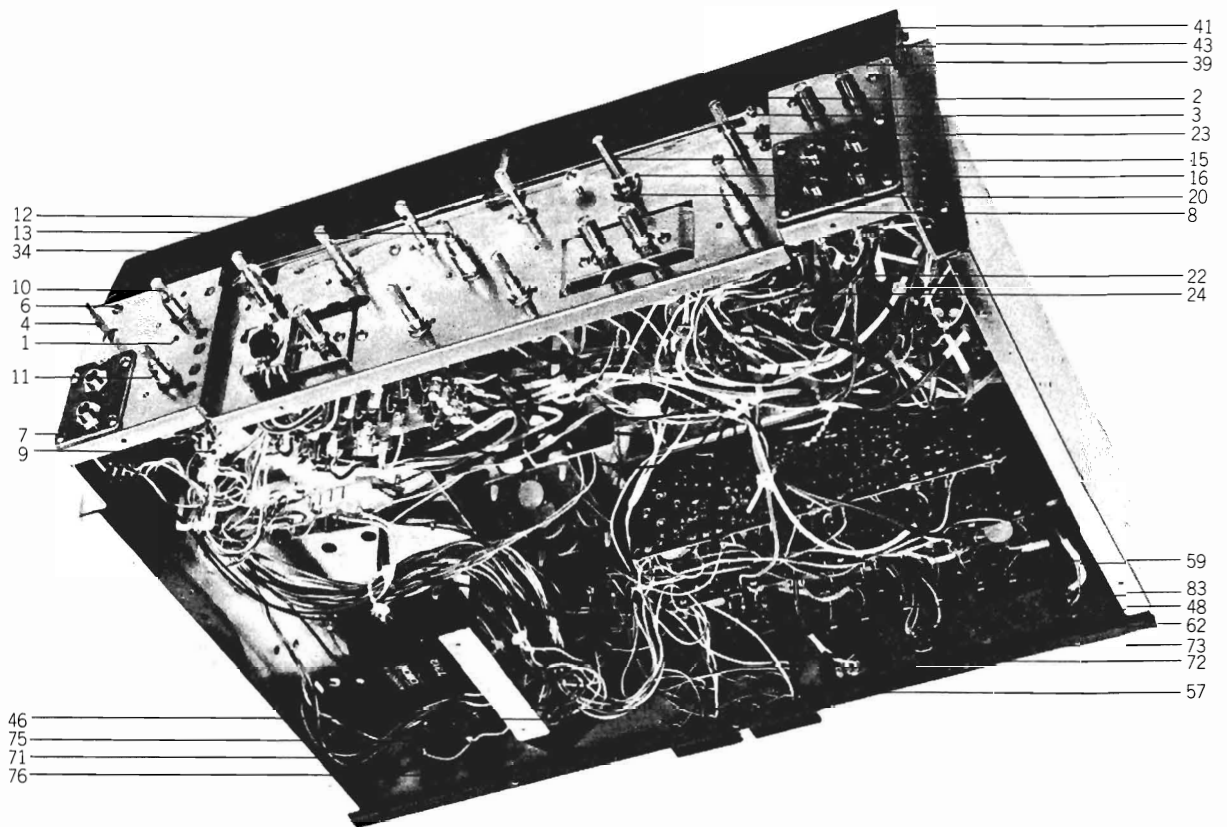

FRONT CHASSIS/REAR PANEL BLOCK

Ref. No.	Parts No.	Description	Schematic No.	Q'ty	Ref. No.	Parts No.	Description	Schematic No.	Q'ty
FRONT CHASSIS BLOCK									
14-1	AZ547942	Front Chassis, w/chassis L,R	96-5018	1	14-57	EJ539796	Fuse Holder 2P	40-1-29	2
14-2	ZS530684	Roller Screw B (L=13)	91-5010	3	14-58x	ZS447772	Tapping Screw #2 3x6 (BR)		4
14-3	MR530662	Roller B (D=10)	91-5009	4	14-59	EJ539763	Wrapping Pin Jack B 4P	31-1-106	5
14-4	ES468448	Lever SW. SDD4LFJO (LPS60122FJ00)	25-4-12	1	14-60	EJ551340	Wrapping Pin Jack B 6P	31-1-102	1
14-5x	EC551160	Ceramic/C. 0.01 μ F(Z) 1.4kVW	24-5-55	2	14-61x	ER428567	Solid/R. RC1/2 2.2M(K)	35-5-4	1
14-6	ZS371856	ISO Screw, binding head 3x5		12	14-62	EJ299305	Jack, 5P Din	31-1-1	1
14-7	ZS447772	Tapping Screw #2 3x6 (BR)		8	14-63	ZS447761	Tapping Screw #2 3x6 (BR) (Black)		4
14-8	EZ585731	Mic, Dub Spacer	96-5040	1	14-64	AA530910	Antenna Channel	91-5029	1
14-9	MZ229138	Wire Bundle Holder N-108	2-35-1	9	14-65	AA562803	Bar Antenna	55-1-19	1
14-10	ES561914	Rotary SW. SR32N 3-8-2 25KC	25-7-34	1	14-66	AA378268	Antenna Support	AA-5552	1
14-11	ES561925	Rotary SW. SR32N 2-8-4 25KC	25-7-32	1	14-67	ZS379451	ISO Screw, round head 4x50		1
14-12	EV562768	Vol. V16L4N 2B 200k Ω	36-6-4	4	14-68x	ZW273914	Spring Washer M4		2
14-13	EV562770	Co-axial 2-throw Vol. V24L5GN 2BL 250k Ω x4	36-23-7	1	14-69x	ZW556132	ISO Nut M4		1
14-14x	ER364983	Carbon/R. RD1/4 18k(J) (Insu. Type)	35-9-5	2	14-70x	ZW551373	Washer (Nylon) D4.2x8x0.5t		2
14-15	MS530752	Tuning Shaft	91-5018	1	14-71	EZ382263	Strain Relief SR-4K-4	2-7-12	2
14-16	AA530741	Tuning Metal	91-5017	1	14-72	AZ544950	Volume Retaining Parts	98-5049	1
14-17x	ZW260122	Washer (Nylon) D6.1x10x1t		2	14-73	EV557897	Vol. V16L4N B 1k Ω	36-6-2	1
14-18x	BF530763	Flywheel	91-5019	1	14-74	ZW552622	ISO Screw, pan head 3x6 (Black)		2
14-19x	ZS462936	ISO Set Screw, hexagon socket 3x5 (Cup/p)		1	14-75	EJ378944	Socket, AC U/L S-1 9122	31-1-47	2
14-20	ZW539583	Nut M11		1	14-76	AA530908	Socket Nut	91-5028	2
14-21x	ZW539594	Washer (SPC) D11.2x16x0.5t		1	14-77	EZ486257	Metal Terminal T-10	32-1-27	2
14-22	AZ545545	Selector SW. Mt. Angle	97-5020	1	14-78	EW540112	AC Cord (CUL) 2.5M	26-3-19	1
14-23	ES561936	Rotary SW. Y7-17-5	25-7-37	1	14-79x	EW524845	AC Cord (J) 2.5M	26-3-31	1
14-24	ES557763	Rotary SW. SR26N 5-15-5 35KH	25-6-63	1	14-80x	EW486797	Power Supply Cord (WG)	26-3-26	1
14-25	AZ547907	Push SW. Mt. Plate	96-5020	1	14-81x	EW315448	Australia Cord (3 core)	26-3-11	1
SCALE MT. CHASSIS BLOCK									
14-26	AZ548188	Scale Plate Mt. Chassis	96-5021	1	14-82x	EZ246936	Strain Relief SR-6W-1 (WG, 3 core)	2-7-8	1
14-27	AA530785	Lamp Case	91-5021	1	14-83	EJ354936	1P Pin-Jack	31-1-32	1
14-28	ZS447772	Tapping Screw #2 3x6 (BR)		15	14-84x	EF575223	Fuse 5A 250V	39-1-50	1
14-29x	EL539684	Fuse Type Lamp 8V 0.3A	28-2-27	6					
14-30	AA548201	Lamp Holder	96-5023	1					
14-31	AZ548190	Lamp Holder Case	96-5022	1					
14-32	EL550045	Cord Lamp 8V 50MA (ST. IND.)	28-2-30	7					
14-33x	SM531336	Illumination Plate, Pointer	91-5065	1					
14-34	EM539685	Tuning Meter KL-218L-26	46-1-68	1					
14-35	AA530820	Meter Case	91-5025	1					
14-36	EJ367986	Fuse Holder 1P AC125V 5A	40-1-8	1					
14-37	AA530818	Meter Mt. Angle	91-5024	1					
14-38	ZS379405	ISO Screw, binding head 3x6		3					
14-39	EM558044	Indicator (2-4ch)	28-2-31	1					
14-40	AA544926	Indicator Support	96-5045	1					
14-41	AA548212	Scale Plate A	96-5024	1					
14-42x	AA548256	Scale Plate B (J)	96-5024	1					
14-43	EJ556143	Canoe Clip (Large)	2-7-35	2					
REAR PANEL BLOCK									
14-44	SP548166	Rear Panel A	96-5025	1					
14-45x	SP548245	Rear Panel B (CSA)	96-5025	1					
14-46	EJ233370	Socket (Volt. Selector) S-18010	40-2-3	1					
14-47	ZW552611	ISO Screw, pan head 3x8 (Black)		11					
14-48	EJ539785	Consent, Speaker (2-throw)	31-1-96	2					
14-49	ZS570385	ISO Tap-tight Screw (pan) 3x8 (Black)		16					
14-50	AA510625	Antenna Terminal Plate 5P	32-1-29	1					
14-51x	ZW348107	ISO Nut M3		5					
14-52x	ZW273802	Toothed Lock Washer M3		3					
14-53x	ZW273778	Earth Lug M3		1					
14-54	ES320016	Slide SW. MFS-201NB	25-3-21	1					
14-55x	ER211320	Carbon/R. RD1/4 1.5k(J) (Stop. Type)	35-10-1	2					
14-56	ZW562015	ISO Screw, binding head 2x4 (Black)		2					

When ordering parts, please describe Parts Number, Serial Number, and Model Number in detail.

FIG. 15 PHOTO OF ASSEMBLY BLOCK

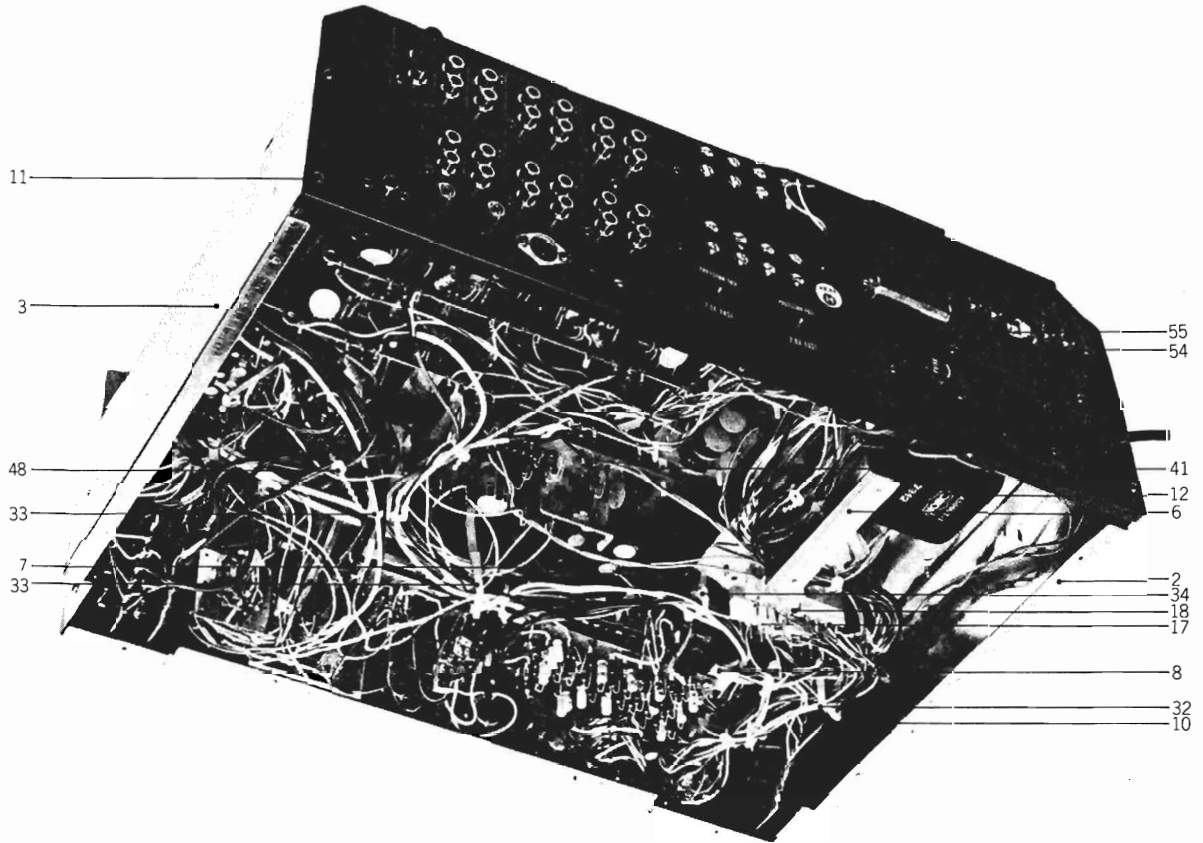
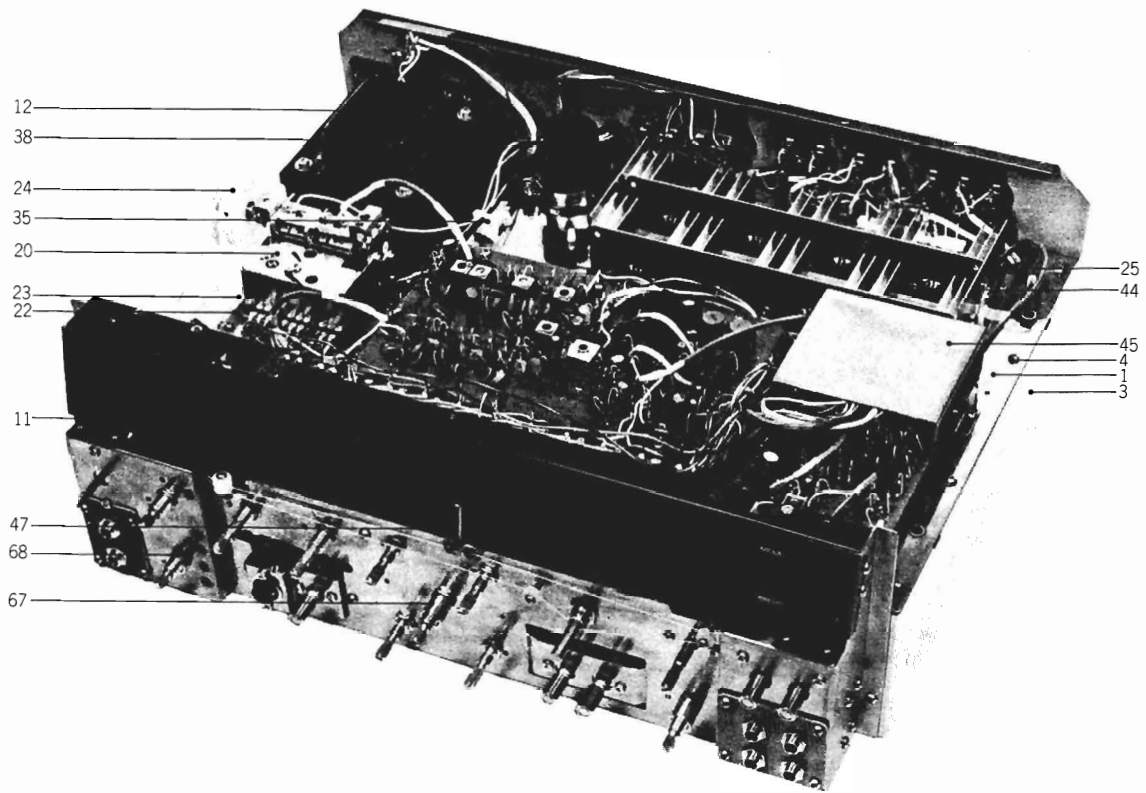

ASSEMBLY BLOCK

Ref. No.	Parts No.	Description	Schematic No.	Q'ty	Ref. No.	Parts No.	Description	Schematic No.	Q'ty
15-1	AZ548032	Main Chassis, w/sub chassis	96-5009	1	15-64x	MZ259233	Wire Band C (CSA)	3A-745	1
15-2	AA532056	Side Plate Left	94-5002	1	15-65x	ZW273881	Earth Lug M4		1
15-3	AA532067	Side Plate Right	94-5003	1	15-66x	ER428567	Solid/R. RC1/2 2.2M(K)	35-54	1
15-4	ZS447772	Tapping Screw #2 3x6 (BR)		61	15-67	AA531371	Stop Collar 2 (L=12.5)	91-5074	2
15-5x	ZW273778	Earth Lug M3		2	15-68	AA531360	Stop Collar 1 (L=2.5)	91-5074	1
15-6	AA532078	Reinforcement Angle A	94-5004	1					
15-7	AZ530695	Reinforcement Angle	91-5011	1					
15-8	AZ548111	P.C. Board Support 3	96-5031	1					
15-9x	ZS371856	ISO Screw, binding head 3x5		2					
15-10	AA548065	Insulator Plate	96-5013	1					
15-11	ZS447761	Tapping Screw #2 3x6 (BR) (Black)		12					
15-12	BT562724	Power Trans. AS-960T-1	38-4-257	1					
15-13x	BT592222	Power Trans. AS-960T-2 (CSA)	38-4-291	1					
15-14x	ZW273914	Spring Washer M4		4					
15-15x	ZW444251	ISO Nut M4		4					
15-16x	ZW273881	Earth Lug M4		1					
15-17	EJ550067	Lug Plate 4P T-5305	33-5-5	3					
15-18	ZS447805	Tapping Screw #2 3x12(BR)		3					
15-19x	EJ254970	Lug Plate KP1L1	33-3-3	1					
15-20	AF562735	Front End FB-112U12 or 21	57-2-29	1					
15-21x	AF562825	Front End FB-112J14 (J)	57-2-30	1					
15-22	AZ548021	Front End P.C. Board	96-5007	1					
15-23	AZ548054	Front End Retaining Base	96-5011	1					
15-24	MR530706	Pulley	91-5012	1					
15-25	ZS321298	ISO Screw, binding head 3x8		9					
15-26x	ZG549011	Tuning Spring	91-5094	1					
15-27x	AZ548133	Roller Mt. Angle	96-5035	1					
15-28x	MR530662	Roller B (D=10)	91-5009	1					
15-29x	MR530651	Roller A (D=14)	91-5008	2					
15-30x	ZW530673	Roller Screw A (L=9)	91-5010	1					
15-31x	ZS530684	Roller Screw B (L=13)	91-5010	1					
15-32	EJ551057	Wire Clip 220-JD481010-0021	2-7-27	3					
15-33	EJ557717	Wire Clip 0017	2-7-26	2					
15-34	EJ514607	Wire Clip 220-JD485210-01 (Nylon)	2-7-18	1					
15-35	EJ557728	Wire Clip 0128	2-7-19	3					
15-36x	EJ510333	Wire Clip 220-JD481610- 0104 (Nylon)	2-7-17	2					
15-37x	EJ551035	Wrapping Terminal 4P T5251	32-1-36	3					
15-38	EC555996	Elect./C. 3300μF 63WV (Lug Type)	24-10-84	1					
15-39x	ER452777	Carbon/R. RD1/4 160kΩ(J) (Insu. Type)	35-9-5	2					
15-40x	ER364994	Carbon/R. RD1/4 39kΩ(J)	35-9-5	2					
15-41	EJ514034	PC Support	2-7-20	16					
15-42x	EZ545602	P.C. Board Support	97-5038	2					
15-43x	EZ548100	P.C. Board Support 2 (Small)	96-5030	1					
15-44	AZ548098	Heat-sink Mt. Plate	96-5017	2					
15-45	AZ547356	SQ Shield	97-5050	1					
15-46x	AA530627	IF P.C. Board Mt. Plate	91-5005	2					
15-47	AA530954	Dial Pointer	91-5039	1					
15-48	MZ229138	Wire Bundle Holder N-108	2-35-1	10					
15-49x	EF563703	Fuse 2A 250V	39-1-50	4					
15-50x	EF562691	Fuse 2.5A 250V	39-1-50	1					
15-51x	EF575223	Fuse 5A 250V	39-1-50	1					
15-52x	EF563657	Fuse 3A 250V	39-1-50	1					
15-53x	EF575932	Fuse 0.8A 250V	39-1-50	1					
15-54	AA539537	Fuse Holder Cover 2P	2-34-78	2					
15-55	ZS552622	ISO Screw, pan head 3x6		2					
15-56x	MZ598318	Fuse P.C. Board Mt. Base (CSA)	98-5101	1					
15-57x	ZS325495	Tapping Screw #2 3x6		5					
15-58x	EA598320	Fuse P.C. Board (CSA)	98-5102	1					
15-59x	EJ539662	Wrapping Post 1x17	32-1-48	7					
15-60x	EJ592064	Fuse Holder, P.C. Board H0006 (CSA)	40-1-36	14					
15-61x	ES379405	ISO Screw, binding head 3x6		2					
15-62x	MZ598498	Heat-sink Barrier (CSA)	96-5052	1					
15-63x	MZ229138	Wire Bundle Holder N-108 (CSA)	2-35-1	3					

When ordering parts, please describe Parts Number, Serial Number, and Model Number in detail.

FIG. 16 PHOTO OF FINAL ASSEMBLY BLOCK



FINAL ASSEMBLY BLOCK

Ref. No.	Parts No.	Description	Schematic No.	Q'ty
FRONT PANEL BLOCK				
16-1	SP547918	Front Panel	96-5027	1
16-2	AA541517	Side Molding A (Right)	91-5082	1
16-3	AA541528	Side Molding B (Left)	91-5082	1
16-4	AA531156	Side Fitting A (Right)	91-5046	1
16-5	AA531167	Side Fitting B (Left)	91-5046	1
16-6x	ZS447805	Tapping Screw #2 3x12 (BR)		6
16-7	AA531044	Front Plate 7	91-5044	1
16-8	AA531145	Fitting 2	91-5045	2
16-9x	AA530976	Cushion, Retaining Plate	91-5043	2
16-10x	ZS447840	Tapping Screw #2 3x8 (BR)		2
16-11	AA545905	Push Button Bush	98-5061	5
ASSEMBLY BLOCK				
16-12x	SP533430	Bottom Plate	94-5035	1
16-13x	ZS447772	Tapping Screw #2 3x6 (BR)		9
16-14x	SA377190	Rubber Foot, LM	LM-404	4
16-15x	ZW419646	Washer (SPC) D4.5x9.8x0.5t		4
16-16x	ZS463375	Tapping Screw #2 4x15 (Truss)		4
16-17	ZW526577	Collar B, Jack	MC-5006	6
16-18x	ZW406416	Tapping Screw #2 3x8 countersunk		3
16-19x	ZS447840	Tapping Screw #2 3x8 (BR)		2
16-20	SK531213	Tuning Knob	91-5050	1
16-21x	ZS446422	ISO Set Screw, hexagon socket 4x8 (cup/p.)		1
16-22	SK531314	Power Knob	91-5060	1
16-23	SK547964	Selector Knob	98-5080	4
16-24	SK531224	Push Button Knob	91-5051	5
16-25	SK531281	Single Knob	91-5057	2
16-26	SK548144	Balance Knob	96-5029	4
16-27	SK548076	Main Volume Knob	96-5014	1
16-28	BC533452	Cabinet	94-5038	1
16-29	ZW548010	Spot Facing Washer	MU-6028	4
16-30	ZS552824	ISO Screw, binding head 4x1 8		4
16-31x	ZW562757	Washer D4.3x11x0.8t		4
16-32	AA545894	Remote Jack Cover	98-5062	1
16-33x	EJ552778	Short Pin Plug P0107	42-1-65	2
16-34x	AA560092	FM Antenna AFM-1B (5003-03)	55-1-18	1
16-35x	AA560081	FM Antenna AFM-1A (5003-04) (J)	55-1-18	1
16-36x	EF562544	Fuse 6A 125V	39-1-47	1
16-37x	EF563657	Fuse 3A 250V	39-1-50	1
16-38x	EF562680	Fuse 5A 125V	39-1-47	1
16-39x	EF562691	Fuse 2.5A 250V	39-1-50	1

When ordering parts, please describe Parts Number, Serial Number, and Model Number in detail.

INDEX

Parts No.	Ref. No. & Symbol No.	Parts No.	Ref. No. & Symbol No.	Parts No.	Ref. No. & Symbol No.	Parts No.	Ref. No. & Symbol No.	Parts No.	Ref. No. & Symbol No.
AA378268	14-66	EC220994	1-C55	EC479621	8-C10, 11	EJ592064	15-60x	ER213030	2-R33
AA510625	14-50	EC220994	4-C5	EC479621	8-C13 to 16	EL539684	14-29x	ER213030	7-R11
AA530627	15-46x	EC228745	3-C10	EC479621	8-C13 to 20	EL550045	14-32	ER213096	8-R22
AA530741	14-16	EC250661	1-C59	EC479621	8-C22	EM539685	14-34	ER213096	8-R31
AA530785	14-27	EC250683	4-C7	EC483142	4-C1	EM558044	14-39	ER213120	1-R7
AA530818	14-37	EC250885	1-C48	EC492142	1-C26 to 34	EO443700	1-T1	ER213715	3-R1
AA530820	14-35	EC250885	1-C53, 54	EC517138	4-C6	EO443766	1-T7	ER304290	1-R37
AA530908	14-76	EC250964	1-C71, 72	EC522551	2-C12	EO443777	1-T8	ER304290	1-R61
AA530910	14-64	EC290520	2-C18, 19	EC522551	2-C15	EO443788	1-L2, 3	ER304290	3-R22, 23
AA530954	15-47	EC290520	3-C4	EC522551	2-C17	EO537232	1-T2	ER304290	8-R3
AA530976	16-9x	EC290520	3-C6	EC538435	2-C3	EO539820	1-L1	ER304290	8-R11
AA531044	16-7	EC290520	3-C13	EC539842	1-C43, 44	ER211320	1-R46	ER304290	8-R25
AA531145	16-8	EC290531	1-C40	EC551160	3-C11	ER211320	2-R40	ER304290	8-R34
AA531156	16-4	EC290531	1-C46	EC551160	5-C1	ER211320	3-R8	ER304402	1-R50
AA531167	16-5	EC313108	2-C2	EC551160	6-C1 to 5	ER211320	4-R1	ER304402	1-R55
AA531360	15-68	EC320040	1-C41, 42	EC551160	14-5x	ER211320	14-55x	ER304402	1-R60
AA531371	15-67	EC320051	1-C47	EC555996	15-38	ER211465	1-R12	ER306360	2-R45
AA532056	15-2	EC321208	1-C57	EC557616	12-C1 to 8	ER211465	1-R18	ER306843	1-R42
AA532067	15-3	EC321221	3-C2	EC557627	5-C5	ER211465	1-R24	ER306843	2-R6
AA532078	15-6	EC321221	5-C4	EC562847	3-C9	ER211465	1-R30, 31	ER306843	7-R12
AA539537	15-54	EC321221	5-C6	ED219464	1-D7 to 9	ER211465	1-R45	ER306887	1-R66
AA541517	16-2	EC329850	4-C10	ED224526	5-D1 to 8	ER211465	1-R51	ER306887	1-R69
AA541528	16-3	EC329883	2-C5	ED224526	5-D11 to 14	ER211465	1-R54	ER306887	2-R4
AA544926	14-40	EC329883	2-C10	ED428264	1-D1 to 6	ER211465	4-R3	ER306887	3-R18
AA545117	5-2	EC331705	1-C52	ED539976	5-D9	ER211465	7-R1	ER306887	4-R5
AA545894	16-32	EC336104	3-C7	ED556514	3-D1	ER211465	7-R15	ER306887	5-R4
AA545905	16-11	EC336148	5-C8	ED558033	6-D1 to 4	ER211465	8-R18	ER306887	5-R10
AA548065	15-10	EC336216	4-C9	ED562814	5-D10	ER211465	8-R27	ER324202	3-R9
AA548201	14-30	EC337500	2-C8	EF562544	16-36x	ER211667	1-R5	ER324202	4-R11
AA548212	14-41	EC338501	7-C1	EF562680	16-38x	ER211667	1-R13	ER336442	1-R9
AA548256	14-42x	EC338501	7-C3	EF562691	15-50x	ER211667	1-R19	ER336442	1-R15
AA560081	16-35x	EC342821	1-C67, 68	EF562691	16-39x	ER211667	1-R27	ER336442	1-R21
AA560092	16-34x	EC346206	7-C2	EF563657	15-52x	ER211667	1-R29	ER336442	1-R33 to 35
AA562803	14-65	EC346590	7-C7, 8	EF563657	16-37x	ER211667	1-R32	ER336442	1-R49
AF562735	15-20	EC346735	4-C2	EF563703	15-49x	ER211667	1-R40	ER336442	2-R1
AF562825	15-21x	EC350706	1-C37	EF575223	14-84x	ER211667	1-R43	ER336442	2-R3
AZ530695	15-7	EC350706	1-C58	EF575223	15-51x	ER211667	1-R47	ER336442	2-R22
AZ544836	10-3	EC350706	1-C60 to 62	EF575932	15-53x	ER211667	1-R52	ER336442	3-R3
AZ544950	14-72	EC350706	1-C73, 74	EI443744	1-IC2	ER211667	1-R58	ER336442	5-R7, 8
AZ545534	8-4x	EC350875	1-C65, 66	EI485291	1-IC1	ER211667	2-R52	ER336442	7-R5
AZ545545	14-22	EC350875	2-C9	EJ233370	14-46	ER211667	7-R14	ER336442	7-R9
AZ547356	15-45	EC354947	3-C1	EJ254970	15-19x	ER211667	8-R17	ER336442	8-R4
AZ547907	14-25	EC354947	3-C5	EJ299305	14-62	ER211757	2-R20, 21	ER336442	8-R7, 8
AZ547942	14-1	EC357827	1-C36	EJ354936	14-83	ER211757	2-R29	ER336442	8-R12
AZ548021	15-22	EC362158	1-C63, 64	EJ367986	14-36	ER211757	2-R42	ER336442	8-R15, 16
AZ548032	15-1	EC368335	2-C7	EJ378944	14-75	ER211757	2-R46	ER336442	8-R26
AZ548054	15-23	EC368335	11-C1	EJ391083	9-J3, 4	ER211757	3-R5	ER336442	8-R35
AZ548098	15-44	EC368357	2-C4	EJ391094	9-J1, 2	ER211757	8-R2	ER336442	12-R9, 10
AZ548111	15-8	EC373296	3-C12	EJ437321	10-J1, 2	ER211757	8-R6	ER342933	2-R10
AZ548133	15-27x	EC377212	3-C3	EJ510333	15-36x	ER211757	8-R10	ER342933	2-R16
AZ548188	14-26	EC377212	3-C8	EJ514034	15-41	ER211757	8-R14	ER342933	2-R41
AZ548190	14-31	EC379214	7-C5, 6	EJ514607	15-34	ER211757	8-R24	ER343078	1-R62, 63
AZ549112	9-4	EC379721	2-C6	EJ514822	13-2	ER211757	8-R33	ER343078	2-R44
AZ562836	3-3	EC379721	7-C4	EJ539662	1-3	ER212016	3-R12	ER346544	2-R15
BA560531	10-1x	EC380621	4-C8	EJ539662	2-2	ER212016	4-R7	ER346544	2-R17
BA560676	6-1x	EC389237	11-C2	EJ539662	4-2	ER212264	2-R9	ER346601	1-R38
BA562274	13-1x	EC390633	1-C69, 70	EJ539662	5-4	ER212264	5-R9	ER346601	2-R26
BA562342	2-1x	EC399690	8-C2	EJ539662	6-2	ER212264	5-R11	ER346601	2-R30
BA562983	8-1x	EC399690	8-C9	EJ539662	8-5	ER212477	1-R10	ER346601	2-R32
BA562994	7-1x	EC403468	5-C2, 3	EJ539662	11-2	ER212477	1-R16	ER346601	2-R51
BA563005	11-1x	EC404256	1-C2 to 25	EJ539662	12-2	ER212477	1-R22	ER346601	5-R12
BA563016	9-1x	EC419231	1-C50	EJ539662	13-3	ER212681	1-R11	ER346994	2-R49
BA563027	12-1x	EC427937	1-C49	EJ539662	15-59x	ER212681	1-R14	ER346994	7-R8
BA563106	1-1x	EC432808	1-C56	EJ539673	7-2	ER212681	1-R17	ER346994	11-R1
BA563117	4-1x	EC443654	1-C35	EJ539763	14-59	ER212681	1-R20	ER347038	3-R7
BA563861	1-2x	EC450527	2-C11	EJ539785	14-48	ER212681	1-R23	ER347038	7-R13
BA570407	5-1x	EC450527	2-C13, 14	EJ539796	14-57	ER212681	1-R28	ER349784	2-R37
BA570914	3-1x	EC450527	2-C16	EJ550012	3-6	ER212681	1-R57	ER349828	1-R36
BC533452	16-28	EC450527	2-C20, 21	EJ550012	9-2	ER212681	1-R71	ER349828	5-R3
BF530763	14-18x	EC450527	4-C4	EJ550012	10-2	ER212681	7-R7	ER349907	1-R2
BT379991	1-T4	EC455354	2-C1	EJ550067	15-17	ER212883	1-R3	ER349942	1-R39
BT380384	1-T5	EC455354	8-C23	EJ551035	15-37x	ER212883	2-R7, 8	ER349942	2-R23
BT427915	1-T3	EC476324	4-C3	EJ551057	15-32	ER212883	3-R6	ER350100	3-R10
BT443610	1-T6	EC476324	8-C5	EJ551340	14-60	ER212883	3-R11	ER352045	2-R36
BT562724	15-12	EC476324	8-C12	EJ552778	16-33x	ER212883	5-R1	ER352045	2-R38
BT592222	15-13x	EC476324	8-C17	EJ556143	14-43	ER213030	1-R53	ER357412	1-R26
EA598320	15-58x	EC476324	8-C21	EJ557717	15-33	ER213030	1-R56	ER357412	3-R13
EC220127	5-C7	EC479621	8-C1	EJ557728	15-35	ER213030	1-R67	ER357412	3-R15
EC220994	1-C45	EC479621	8-C3, 4	EJ557910	8-J3x	ER213030	1-R70	ER357456	1-R41
EC220994	1-C51	EC479621	8-C6, 7, 8	EJ558022	5-5x	ER213030	2-R31	ER357456	1-R64, 65

INDEX

Parts No.	Ref. No. & Symbol No.	Parts No.	Ref. No. & Symbol No.	Parts No.	Ref. No. & Symbol No.	Parts No.	Ref. No. & Symbol No.	Parts No.	Ref. No. & Symbol No.
ER357456	1-R68	ET452531	3-TR5, 6	ZS462936	14-19x				
ER357456	2-R11 to 14	ET510693	1-TR5	ZS463375	16-16x				
ER357535	1-R48	ET517994	5-TR2	ZS530684	14-2				
ER357535	4-R9	ET517994	5-TR4	ZS530684	15-31x				
ER357570	2-R5	ET539122	5-TR3	ZS552622	15-55				
ER357570	2-R34, 35	ET539987	2-TR1 to 6	ZS552824	16-30				
ER357570	4-R4	ET539987	3-TR1	ZS570385	14-49				
ER357570	8-R23	ET539987	4-TR1, 2	ZW260122	14-17x				
ER357570	8-R32	ET539987	7-TR1, 2	ZW270191	9-3				
ER357570	11-R2	ET539987	8-TR1 to 8	ZW270191	10-4				
ER361528	1-R1	ET554016	1-TR1 to 4	ZW273778	14-53x				
ER361528	1-R44	ET557998	5-TR1	ZW273778	15-5x				
ER361528	2-R50	ET562858	3-TR2, 3, 4	ZW273802	14-52x				
ER361607	7-R4	ET591366	1-TR6 to 8	ZW273881	15-16x				
ER362441	5-R2	EV383398	3-VR1	ZW273881	15-65x				
ER362441	8-R21	EV409858	3-VR2	ZW273914	14-68x				
ER362441	8-R30	EV539831	1-VR1	ZW273914	15-14x				
ER362485	7-R6	EV555941	7-VR1, 2	ZW348107	3-5				
ER362520	2-R24	EV557897	14-73	ZW348107	14-51x				
ER363644	1-R4	EV562768	14-12	ZW406416	16-18x				
ER364948	3-R2	EV562770	14-13	ZW419646	16-15x				
ER364983	14-14x	EW315448	14-81x	ZW426622	3-7x				
ER364994	15-40x	EW486797	14-80x	ZW444251	15-15x				
ER371946	4-R8	EW524845	14-79x	ZW526577	16-17				
ER371946	7-R3	EW540112	14-78	ZW530673	15-30x				
ER371946	12-R1 to 8	EZ246936	14-82x	ZW539583	14-20				
ER379473	4-R6	EZ382263	14-71	ZW539594	14-21x				
ER379552	2-R19	EZ486257	14-77	ZW548010	16-29				
ER379596	3-R19	EZ545602	15-42x	ZW551373	14-70x				
ER380406	1-FL4	EZ548100	15-43x	ZW552611	14-47				
ER380417	1-FL4	EZ548234	3-2	ZW552622	14-74				
ER380711	1-R6	EZ585731	14-8	ZW556132	14-69x				
ER380711	8-R1	MR550651	15-29x	ZW562015	14-56				
ER380711	8-R5	MR530662	14-3	ZW562757	16-31x				
ER380711	8-R9	MR530662	15-28x						
ER380711	8-R13	MR530706	15-24						
ER380755	2-R27	MS530752	14-15						
ER380755	4-R12	MZ229138	14-9						
ER380913	3-R14	MZ229138	15-48						
ER381723	2-R39	MZ229138	15-63x						
ER392850	4-R10	MZ259233	15-64x						
ER399060	2-R48	MZ598318	15-56x						
ER404087	8-R19	MZ598498	15-62x						
ER404087	8-R28	SA377190	16-14x						
ER407316	2-R18	SK531213	16-20						
ER407316	2-R43	SK531224	16-24						
ER407316	2-R47	SK531281	16-25						
ER419556	2-R28	SK531314	16-22						
ER419556	4-R13	SK547964	16-23						
ER420232	1-R59	SK548076	16-27						
ER423753	2-R25	SK548144	16-26						
ER423753	7-R2	SM531336	14-33x						
ER428567	14-61x	SP533430	16-12x						
ER428567	15-66x	SP547918	16-1						
ER430007	3-R4	SP548166	14-44						
ER430007	7-R10	SP548245	14-45x						
ER430007	8-R20	ZG549011	15-26x						
ER430007	8-R29	ZS321298	3-8						
ER430086	2-R2	ZS321298	15-25						
ER443878	4-R2	ZS325495	15-57x						
ER452542	3-R20	ZS371856	8-3x						
ER452777	15-39x	ZS371856	14-6						
ER536984	5-R6	ZS371856	15-9x						
ER539818	1-FL1 to 3	ZS379405	8-2x						
ER556064	3-R16, 17	ZS379405	14-38						
ER556795	3-R21	ZS379451	14-67						
ER559034	5-R5	ZS446422	16-21x						
ER559034	10-R1 to 4	ZS447761	14-63						
ES320016	14-54	ZS447761	15-11						
ES379405	15-61x	ZS447772	5-3						
ES468448	14-4	ZS447772	14-7						
ES513922	1-SW1	ZS447772	14-28						
ES551272	12-SW1	ZS447772	14-58x						
ES557763	14-24	ZS447772	15-4						
ES561914	14-10	ZS447772	16-13x						
ES561925	14-11	ZS447805	15-18						
ES561936	14-23	ZS447805	16-6x						
ES562781	8-SW1	ZS447840	16-10x						
ES591131	11-SW1	ZS447840	16-19x						
ET398711	1-TR9, 10	ZS450832	3-4						

SECTION 3
SCHEMATIC DIAGRAM

AS-960

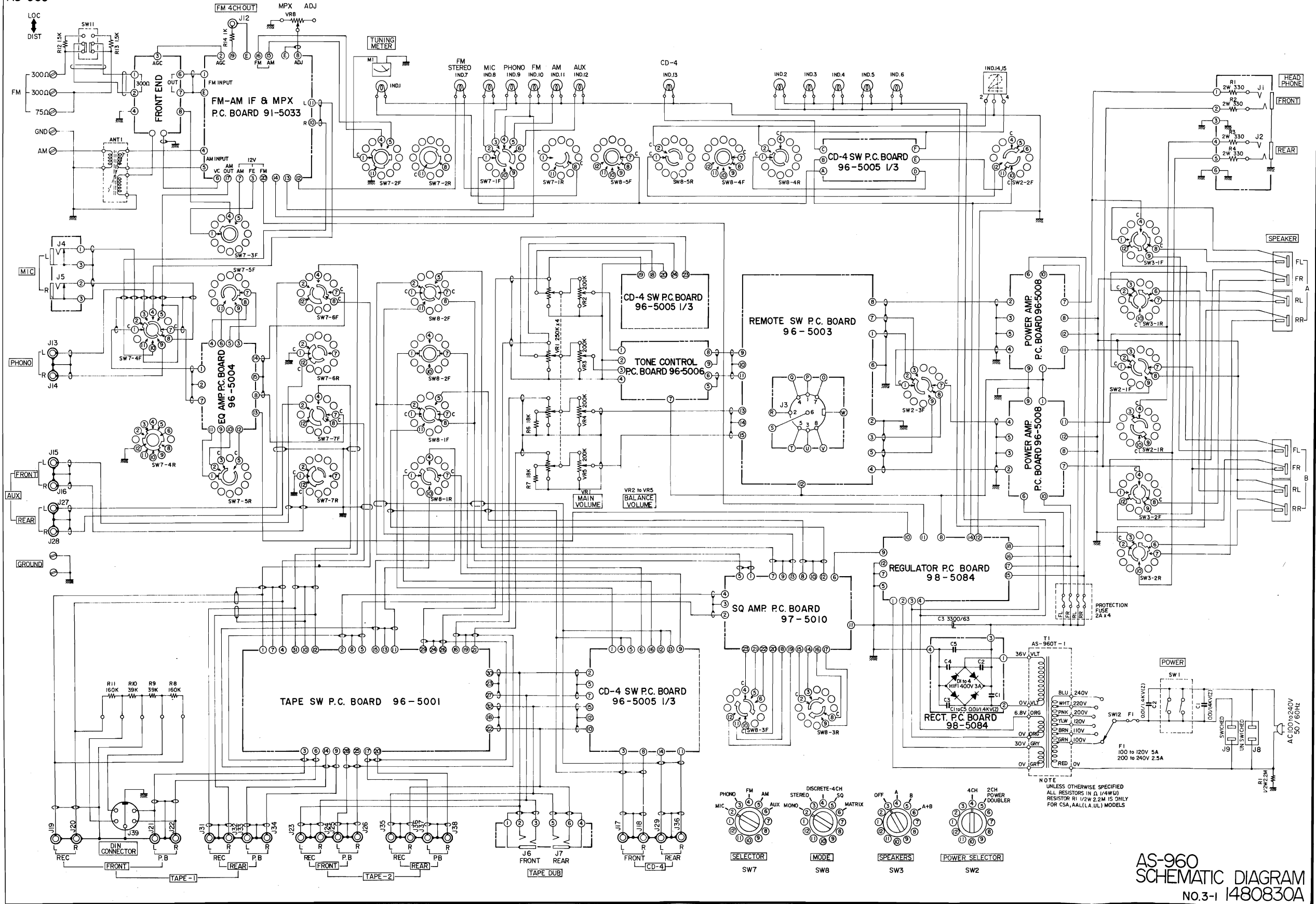

AS-960
SCHEMATIC DIAGRAM
No.3-1 1480830A

FM - AM IF & MPX P.C. BOARD 91 - 5033

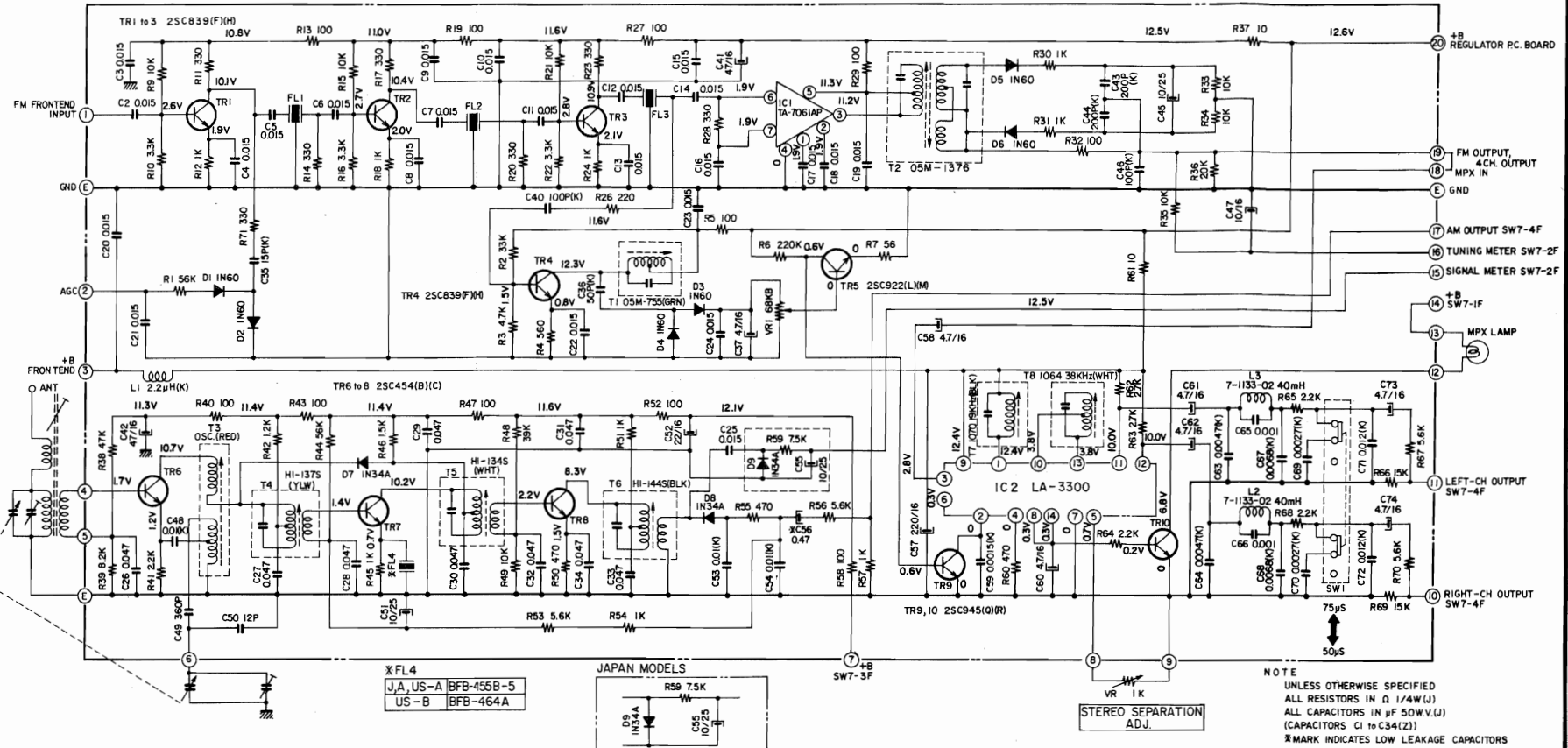

X FL4
 J.A. US-A BFB-456B-5
 US-B BFB-464A

JAPAN MODELS
 D5 IN24A
 C55 10/25

NOTE
 UNLESS OTHERWISE SPECIFIED
 ALL RESISTORS IN Ω (1/4W(J))
 ALL CAPACITORS IN μF (50W.V(J))
 (CAPACITORS C1 TO C34(2))
 * MARK INDICATES LOW LEAKAGE CAPACITORS

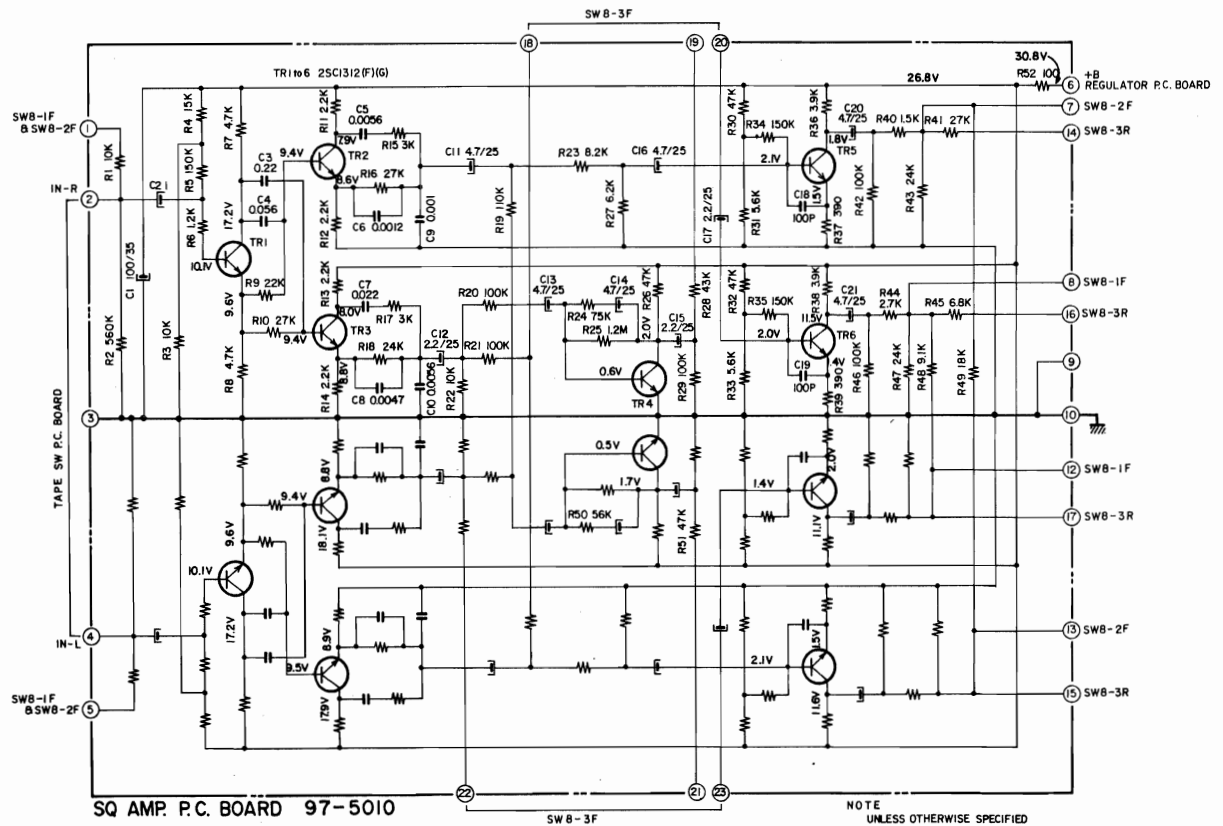

NOTE
 UNLESS OTHERWISE SPECIFIED
 ALL RESISTORS IN Ω (1/4W(J))
 ALL CAPACITORS IN μF (50W.V(J))

